

EastmanTM Copolyesters and Alloys

Processing and Mold Design Guidelines

Proper mold design and machine set-up are essential parts of a quality molding operation. This publication is intended to assist you in the design or conversion of injection-mold tooling and in machine set-up to process EastmanTM copolyesters and alloys.

Investing in high-quality molds can reduce costs and increase profits over the entire life of the mold. A well-designed, quality-built mold made from durable materials and incorporating good cooling and venting will last longer, require fewer repairs, increase quality of production parts, decrease scrap, and shorten cycle time.

These advantages are often overlooked when the up-front mold costs are totaled. These costs can lure companies into taking short cuts in design rather than investing in high-quality molds with precise control systems, which could save money on every shot made.

Eastman engineering resins like EastarTM copolyesters and DuraStarTM and EastalloyTM polymers may be more demanding to mold than commodity polymers. However, with the proper mold design and machine set-up, they can be routinely processed. After reading this information, you will be better equipped to design a mold for EastmanTM polymers or to communicate this information to your moldmaker, and to select the proper machine set-up and processing conditions to mold high-quality parts.

Contents

Part I Mold Design	1
Design for Moldability	1
Mold Filling Analysis	1
Stress Concentration Factors	2
Coring Thick Wall Sections	2
Rib and Boss Design	3
Cooling	4
Suggested Mold Temperatures	4
Mold Shrinkage and Warpage	4
Suggested Cooling Line Spacing	4
Core Cooling Techniques	5
Providing Turbulent Coolant Flow	6
Notes on Cooling	7
Why Corners Are Critical Cooling Areas	8
Sprue Design	9
Sprue Cooling	9
Spiral Cooling Sprue Insert	10
High-Conductivity Sprue Bushing	10
Mold/Sprue Cooling Example	11
Hot Sprues	11
Runner Design	11
Runner Cross Section	12
Half-Round Runner	12
Gate Design	12
Avoid Gating Into Thin Sections	13
Tunnel Gate	14
Fan Gate	14
Edge Gate	14
Gating Parts With Maximum Dimensions of 50 mm (2 in.) or Less ..	15
Hot Runner Systems	15
Design Guidelines	15

Hot Drops	16
Valve Gates	18
Processing Conditions Using Hot Runner Systems	18
Venting and Ejection	19
Typical Venting in Molds Designed for Eastman™ Polymers	19
Ejection Systems in Molds Designed for Eastman™ Polymers	19
Alloys for Mold Construction	19
Family Molds	20
Mold Polishing and Texturing	21
Mold Polishing	21
Texturing Mold Surfaces	21
Texturing Methods	21
Preventing Surface Defects	21
Draft Angle Guidelines	22
Using Zero Draft	22
Mold Surface Treatment to Aid Ejection	22
Poly-Ond® Coating	22
Tungsten® Disulfide Coatings	23
Nicklon® Coating	23
Part II Processing	24
Choosing the Molding Machine	24
Machine Size	24
Clamping Force	24
Injection Speed	24
Screw and Barrel Design	24
Nozzles	25
Periodic Inspection	26
Drying	26
Equipment	26
Conditions	27
Moisture Measurement	29

Dryer Troubleshooting	29
Injection Molding	32
Molding Conditions	32
Trial Preparation and Operation	33
Start-up	34
Production Molding	34
Production Start-up	34
Use of Regrind	35
Shutdown	35
Packaging and Part Handling	35
Part III Secondary Operations	36
Methods for Joining Parts Made of Eastman™ Polymers	36
Solvent Bonding	36
Adhesive Systems	36
Ultrasonic Welding	37
Ultrasonic Staking	38
Heat Staking	38
Welding Similar Materials	39
Other Fastening Techniques	39
Part IV Troubleshooting	40
Troubleshooting Guide	40
Descriptions of Terms in Troubleshooting Guide	40
Troubleshooting Guide: Molding Amorphous Eastman™ Polymers ..	42
“Reading” Parts as They Are Moldeed	43
Part Failure: Causes and Analysis	43
Form 1—Pretrial Preparation	44
Form 2—Molding Conditions Record	45
Form 3—Form for Identifying Problems That Are Causing Scrap	46

Part I Mold Design

Design for Moldability

Moldability as well as product performance can be enhanced by proper part design features.

Good design for moldability includes:

- Providing for reasonable flow length.
- Appropriate weld line location.
- Moderate injection pressures.
- Minimum clamp requirements.
- Minimum scrap rate.
- Easy part assembly.
- Minimal or no secondary operations such as degating, painting, and drilling.

Good design helps minimize:

- Molded-in stress.
- Flash.
- Sink marks.
- Surface blemishes.
- Many other common molding defects that reduce quality or productivity.

The ability to fill a mold with reasonable injection pressures is greatly influenced by the wall thickness of the part. Spiral flow data are helpful in choosing appropriate wall thickness. Gate location and wall thickness can be varied to achieve the best balance of part weight, clamp tonnage requirements, and weld line location.

Mold Filling Analysis

Computer-aided mold filling analysis is particularly useful in designing molds for larger, asymmetric parts. Flow patterns can be observed

to determine whether any flow imbalances exist. Flow imbalances can be corrected by adjusting wall thicknesses, placement of flow leaders, and/or relocating the gate. Imbalanced fill can result in underpacked areas or stalled melt flow fronts that become cool and difficult to restart, causing molded-in stress and nonfill conditions.

Mold filling analyses are critically dependent on the viscosity/temperature/shear rate relationship of the molten plastic. Mold filling analysis accepts data for the parameters shown under “Inputs” and is capable of supplying the information shown under “Graphic Outputs.”

Inputs	Graphic Outputs
Material flow characteristics	Flow and fill patterns
Heat transfer properties	Weld line locations
Melt temperature	Pressure to fill
Mold temperature	Pressure patterns
Runner and gate size and location	Clamping force needs
Part and mold design	Temperature patterns
	Shear patterns
	Filling
	Temperatures
	Shear thinning
	Freezing and reheating (temporary stoppage of flow)

Using mold filling analysis, if a factor in the input is changed, effects on moldability can be seen quickly. For example, changing gate location will show the differences in fill patterns, weld lines, pressures needed, and other characteristics of the molding process.

Eastman's analyses also make extensive use of its knowledge of:

- Thermal conductivity.
- Specific heat.
- Melt density.
- Rheological characteristics of the materials involved.

All of these values vary with temperature and must be known accurately for the complete range of processing temperatures.

Stress Concentration Factors

Stress concentrations are areas that, by the nature of their design, tend to concentrate or magnify the stress level within a part. This increase in localized stress may allow the part to fail prematurely by serving as a crack-initiation point. Design features that can serve as stress concentrators are:

- Holes and slots.
- Corners.
- Ribs, gussets, and posts.
- Sharp wall thickness transitions.
- Surface roughness.
- Bosses.
- Notches or grooves.

Inside corners are especially critical. The curve in Figure 1 shows how the stress concentration factor in an inside corner will increase rapidly as

the radius decreases. If the radius is very small or if there is no radius, stress levels will be very high. On the other hand, if the inside radius is too large, a thick section will be formed, which can lead to high levels of shrinkage and molded-in stress. The best radius value is a compromise between these two behaviors. In general, a radius $\frac{1}{8}$ to $\frac{1}{4}$ the wall thickness is suggested for most inside corners, with a minimum radius of 0.4 mm (0.015 in.) in most cases.

Figure 1

Stress Concentration Factors

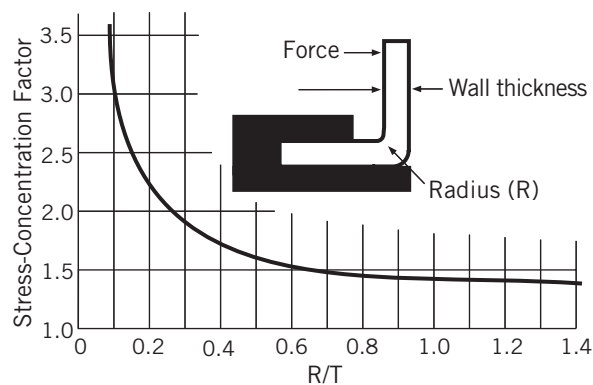

Courtesy of S.P.I. Plastics Engineering Handbook

This curve gives an indication of the proper radius to be used for a given wall thickness.

Coring Thick Wall Sections

A part can rarely be designed with uniform wall thickness because of such features as ribs and bosses. When wall thickness is not uniform, it affects moldability, molded-in stress, color uniformity, and structure.

One method of providing uniform wall thickness is to core thick sections of a part. Often, a coring pattern can be chosen that reduces the thick sections while incorporating structural features such as ribs, gussets, and bosses into the part.

Rib and Boss Design

A rib can be thought of as a simple projection off the part wall. Generally, ribs should be designed with a thickness of $\frac{1}{2}$ the wall thickness to avoid a thick section at the base of the rib, which can cause sink marks on the opposite side of the wall. Designers typically try to limit rib height to 3 times the wall thickness; if the height is much more, the rib tip may become dangerously thin, and the rib may be subject to buckling (see Figure 2). However, for parts with fewer structural requirements, rib height-to-thickness ratios as high as 18:1 have been used.

Ribs are generally spaced at a distance at least twice the wall thickness to allow enough steel between the ribs for adequate cooling. A draft angle of 1° is suggested to allow proper part ejection from the mold.

Finally, be sure to add a radius at least 0.2 to 0.5 times the wall thickness at the base of the rib to reduce stress concentration effects.

A boss can be thought of as a round rib; therefore, many of the same design principles apply (see Figure 3). To avoid thick sections, stand bosses apart from side walls, reinforcing them with gussets or ribs for rigidity. The boss hole length-to-diameter ratio should be 5:1 or less. A longer core pin will be subject to poor cooling and deflection under injection pressures. A lead-in area should be provided at the top of the boss to keep stresses in this area low when the screw or insert is used. Again, a radius of $\frac{1}{8}$ the wall thickness, or 0.4 mm (0.015 in.), whichever is larger, should be placed at the base of the boss.

Figure 2

Typical Rib Design Guidelines

- Rib height-to-thickness ratio should be 3:1 or less in most cases.
- Spacing between ribs should be at least 2 times the wall thickness.

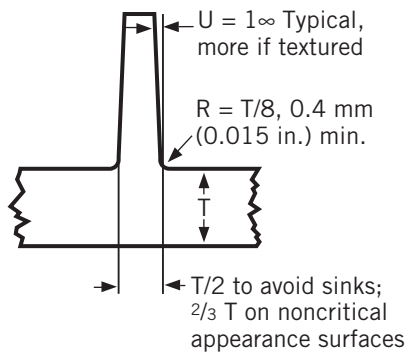
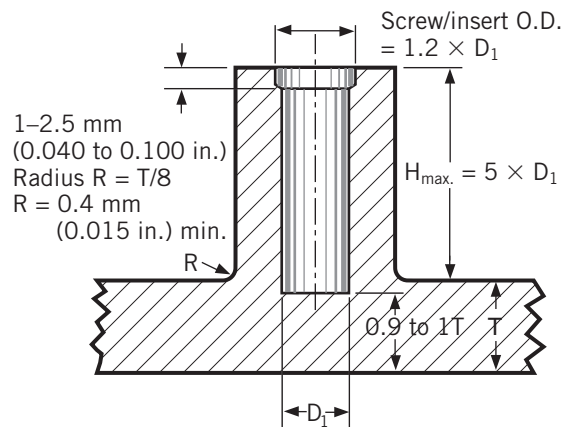

Figure 3

Typical Boss Design



Cooling

By designing parts so that they can be cooled properly, you can obtain lower cycle times and high-quality parts while reducing cost.

Good cooling is absolutely critical when designing molds to run Eastman™ amorphous polymers.

Some effects of poor cooling are:

- Increased cycle time.
- Uneven cooling across parts or part-to-part.
- High levels of residual stress.
- Increased warpage.
- Sticking and difficulty in ejection.

Although all of the above are potentially serious problems, the most common difficulty when running Eastman™ polymers is sticking and difficulty in ejection.

We cannot place enough emphasis on the importance of good mold cooling, especially in cores. By following good core-cooling principles, you can greatly increase your processing window and success in part performance.

Suggested Mold Temperatures

Adequate cooling lines should be provided to accurately control mold temperatures to these suggested levels:

- Eastalloy™ DA Series polymers: 15° to 50°C (60° to 120°F)
- Eastar™ and DuraStar™ polymers: 15° to 40°C (60° to 100°F)
- Eastar™ PETG polymers: 15° to 25°C (60° to 90°F)
- Eastman Tritan™ polymers: 38° to 66°C (100° to 150°F)

In some cases, the use of tower or normal water is adequate. However, the use of chillers is **strongly** encouraged to ensure a proper supply of cool water to molds. Properly sized pumps and supply lines to the molds are also critical.

Mold Shrinkage and Warpage

Key factors in minimizing warpage include:

- Uniform wall thickness.
- Consistent mold temperatures.

A uniform wall:

- Promotes even flow.
- Minimizes shear heating.
- Reduces molded-in stress.
- Tends to minimize warpage.

A uniform mold temperature helps to ensure even heat transfer from both wall surfaces. This will leave the part in a balanced condition, provided the wall thickness is uniform. The important factor is control. The mold should be designed for adequate control of the temperature in the range required for the material being processed. This will not only decrease the amount of residual stress but will also permit reduction of cycle time.

Suggested Cooling Line Spacing

Figure 4 shows the suggested layout of drilled cooling lines for a large part.

Cooling lines should be spaced 2.5 to 3 diameters apart (on center) and 1.5 to 2 diameters away from the surface of the part.

Uniform placement of cooling lines, as shown, will help ensure equal and adequate cooling of the part.

Figure 4
Cooling Line Spacing

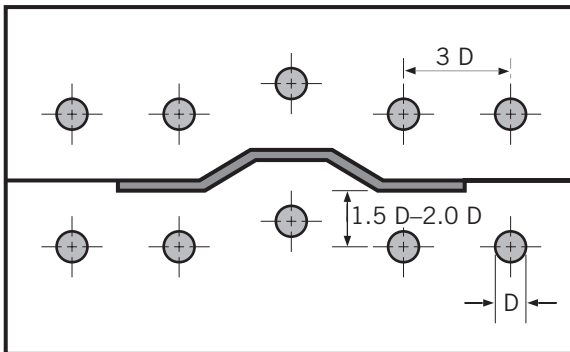

Core Cooling Techniques

There are many methods of achieving proper core cooling including:

- Baffles.
- Bubblers.
- Highly conductive alloys.
- Circular cooling channels around cavity and core inserts.

Any of these methods are suitable, provided the heat removal capacity is sufficient to maintain uniform temperatures down the length of the core. Although proper core cooling potentially adds to mold construction costs, it will pay off in reduced cycle time and improved part quality once the mold goes into production.

Baffles and bubblers are two of the most common methods used to provide core cooling. A typical baffle configuration is shown in Figure 5. With this configuration, a thin blade is inserted down the length of the bore. This divides the bore into 2 semicircular flow channels. Water travels up the length of the core on one side of the baffle blade and then down and out the opposite side of the blade.

Figure 5
Typical Baffle Configuration

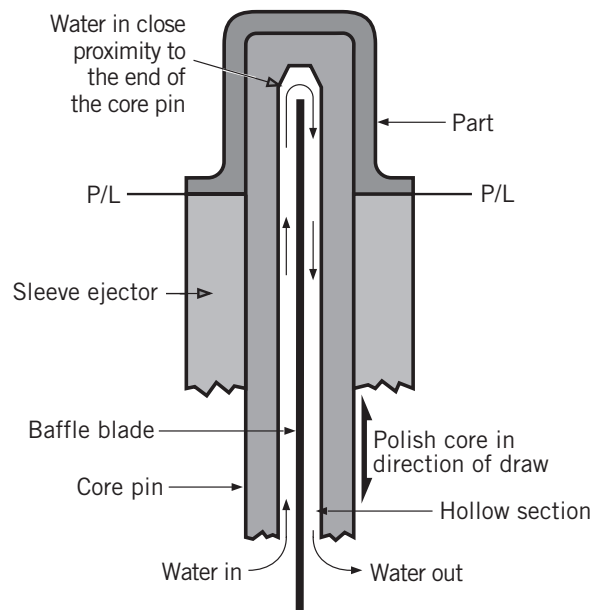

A typical bubbler configuration is shown in Figure 6. A bubbler is very similar to a baffle, except water is supplied to the end of the core with a bubbler tube. Water returns from the core through the annular space between the bubbler tube OD and the core ID.

Figure 6

Typical Bubbler Configuration

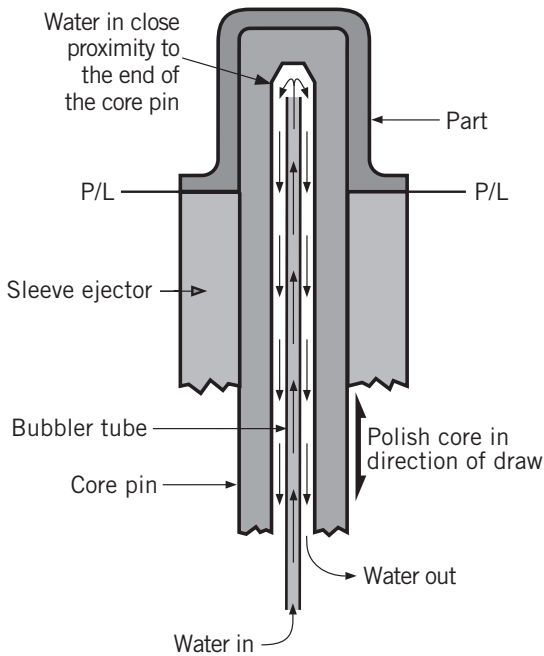

Regardless of the core cooling method selected, several key design points relating to the use of Eastman™ polyesters/copolyester and long core geometries are listed below:

- Water channels should come in close proximity to the end of the core to ensure proper heat removal from this area.
- Polishing core surfaces in the direction of draw to a smooth finish minimizes the required ejection forces.
- Eliminate any flow restrictions in water supply lines.
- Heat transfer is optimized with turbulent water flow through the baffle or bubbler.

Providing Turbulent Coolant Flow

One effective and critical technique for cooling is to ensure that turbulent water flow exists in the cooling lines. If the water flow is laminar, the heat from the mold goes only into the outer layer of the water as it flows through the channels. The outer layers of water do not mix with the cooler inner layers, and the cooling potential is not fully utilized.

Turbulent flow is achieved when the Reynolds number goes above 4,000. The best cooling exists when this number is between 4,000 and 5,500. A Reynolds number below 2,000 indicates laminar flow. This provides only 1/3 the cooling of turbulent flow.

Calculating Reynolds Number

Formulas for calculating Reynolds number follow. When laying cooling lines, plug the appropriate numbers for the variables into the formulas and check the magnitude of the resulting number. Use the values for the kinematic viscosity of water at various temperatures that are shown in Table 1. Viscosity is dependent on temperature.

Calculating Reynolds Number—Metric Units

V = Fluid velocity in meters/second

D = Diameter of passage in millimeters

Q = Coolant flow rate in liters/minute

n = Kinematic viscosity in centistokes

$$N_r = (990 \cdot V \cdot D) / n \text{ or } (21,391 \cdot Q) / (D \cdot n)$$

Rule of Thumb: At least 0.3 times the cooling line diameter (mm) is needed as liters per minute (l/min) flow rate to achieve turbulent flow.

Calculating Reynolds Number—English Units

V = Fluid velocity in feet/second

D = Diameter of passage in inches

Q = Coolant flow rate in gallons/minute

n = Kinematic viscosity in centistokes

$$N_r = (7,740 \cdot V \cdot D) / n \text{ or } (3,160 \cdot Q) / (D \cdot n)$$

Rule of Thumb: At least 2 times the cooling line diameter (inches) is needed as gallons per minute (gpm) flow rate to achieve turbulent flow.

Note:

- Reynolds number must be calculated for each area of the mold having different cooling line diameters.
- A water line in parallel should have the actual flow rate recalculated if the measured flow occurs prior to branching.
- A pressure differential of 0.138 MPa (20 psi) is typically needed to achieve a good flow rate.

Table 1

Kinematic Viscosity for Water

°C	(°F)	Viscosity, Centistokes
0	(32)	1.79
4	(40)	1.54
10	(50)	1.31
16	(60)	1.12
21	(70)	0.98
27	(80)	0.86
32	(90)	0.76
38	(100)	0.69
49	(120)	0.56
60	(140)	0.47
71	(160)	0.40
82	(180)	0.35
93	(200)	0.31
100	(212)	0.28

It is common to find a pressure drop well below 0.138 MPa (20 psi) from inlet to outlet supplies in molding shops. This typically occurs when the number of molding machines has been increased without upgrading the water supply system.

If there is a large temperature difference from inlet to outlet, it is **NOT** an indication of good cooling. Rather, it can be a warning that greater flow rates are required to remove even more heat. The optimum condition for heat dissipation and removal is to have only a few degrees of difference in temperature from inlet to outlet.

Notes on Cooling

- Maintain a clean system. This can be achieved by:
 - Glycol additives.
 - Rust inhibitors.
 - Stainless steel—no rust, but lower heat transfer.
 - Demineralized water.
 - Filtration.
 - Periodically flushing the coolant channels.
- Adding ethylene glycol increases the viscosity of the coolant. Consequently, the convective heat transfer coefficient and the rate of heat transferred from the mold are reduced. For example, doubling the viscosity lowers the heat transfer coefficient by 30%. A 10-fold increase in viscosity (50% ethylene glycol compared to water) can reduce the coefficient by a factor of 3.

- Increasing cooling channel diameters without maintaining velocity will result in a decrease in the total heat removed in a given channel. If turbulent flow is maintained, empirical correlations show that doubling the diameter while keeping *flow volume* (gpm) constant results in approximately 40% less heat transferred in spite of the fact that the area increases.
- Theoretically, for turbulent flow, keeping the same coolant *velocity* while increasing cooling channel diameter will provide a significant increase in heat transferred to a given flow channel. For example, if the diameter is doubled, then the heat transferred should increase approximately 80%.

Note, however, that if one follows the “rule of thumb” on spacing of cooling channels, fewer larger diameter channels will fit around the mold cavity and these will be farther away from the hot plastic. This constraint makes it difficult to show real gains in heat removal by increasing cooling channel diameter.

Why Corners Are Critical Cooling Areas

Figure 7 illustrates that there is approximately 3 times the steel mass on the outside of a corner than on the inside. Thus, it is much easier to remove heat from the plastic on the outside than on the inside because there is more steel in which to place cooling. This concept also holds true for cores in general: they are more difficult to cool than cavities, especially as the size of the cores decreases. To overcome this effect, good core cooling is critical.

Figure 8 shows how ejector pins are commonly placed in the corners of box-shaped parts. With the difference in steel mass between the cavity and core of the mold, as well as the air gaps at the ejector, it is nearly impossible to cool these corners properly. The outside of the part cools first and solidifies, whereas the inside cools slowly, resulting in more shrinkage. The end result is part warpage and high levels of molded-in stress.

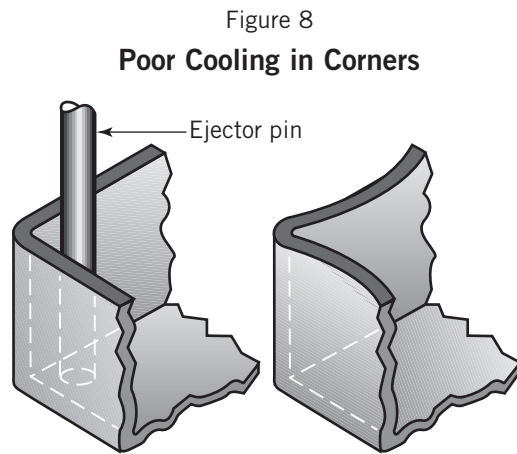
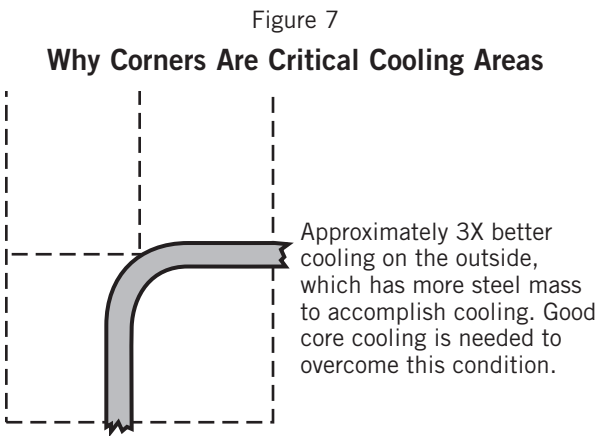
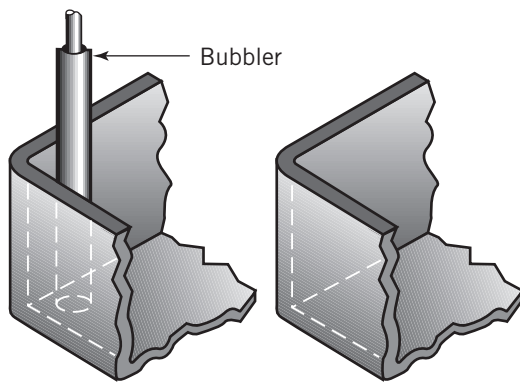

Figure 9 shows how to resolve this situation. Place a bubbler or baffle in the corner to remove heat from that section of the mold. This will help reduce warpage and lower molded-in stress. The ejector pins or blades will need to be moved to other locations or ejection could be accomplished by specifying the use of stripper plates in a new mold.

Figure 9
Provide Good Cooling in Corners to Reduce Warpage



Sprue Design

Proper sprue design is important for good molding and for easy removal of the part from the mold. Sprue design for molds running Eastman™ polymers is important because:

- Polyester materials tend to stick to tool steel when hot.
- The sprue is so thick that it is the hottest and one of the most difficult areas to cool.

As shown in Figure 10, a 6.25-cm/m (0.750-in./ft) taper included angle (about 3.0°) on the sprue and a maximum sprue length of 80 mm (3 in.) is suggested. To aid ejection, polish the sprue in the draw direction. Put a generous radius at the junction of the sprue and runner system to avoid breakage during ejection. Place

an ejector pin under the sprue puller rather than an air poppet valve. An air poppet here would cause a hot spot and impede cooling.

Figure 10
Sprue Design

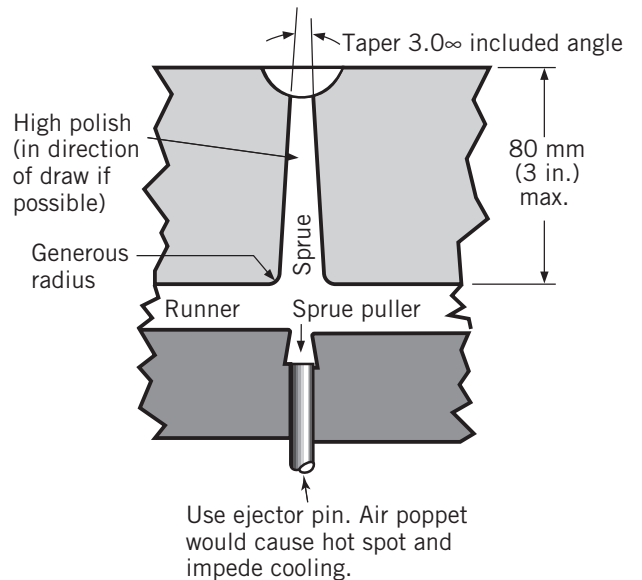

Sprue Cooling

In Figure 11, upper and lower cooling line circuits are shown around the sprue to aid in cooling. The sprue bushing should be assembled with a slight (0.005-mm or 0.2-mil) interference fit to ensure good heat transfer from the bushing into the mold plate.

Figure 11
Sprue Cooling

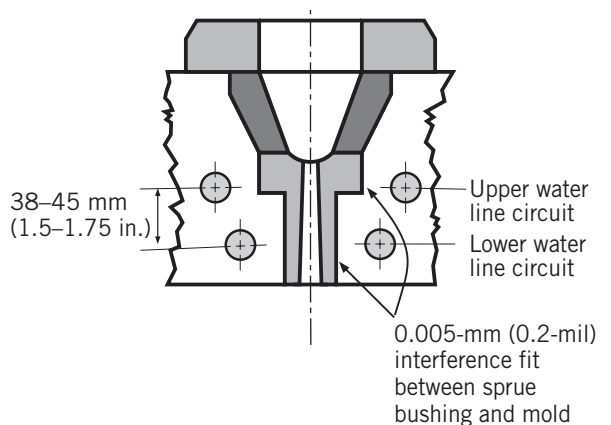

Spiral Cooling Sprue Insert

Figure 12 shows another effective approach to removing heat from the sprue or long cores. This sprue bushing contains a double-helix cooling channel design with water flowing up and around the sprue, then back down again.

Figure 12
Spiral Cooling Sprue Insert

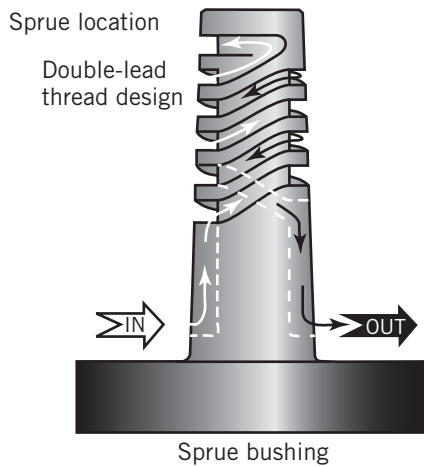

High-Conductivity Sprue Bushing

Many Eastman customers are successfully using the high-conductivity sprue bushings shown in Figure 13. The bushing is made from a high-conductivity copper alloy. It contains a hardened 420 stainless steel nozzle seat to insulate from nozzle heat and for wear resistance. This is effective in reducing sprue sticking, increasing sprue rigidity for pickers and grabbers, and cutting cycle time. With this sprue bushing, a standard sprue taper of 42 mm/m (0.5 in./ft) has been found to be acceptable for good heat transfer.

It is **strongly** suggested that customers install these sprue bushings in new molds and when modifying existing molds to process Eastman™ polymers. They are available worldwide from:

Performance Alloys and Services, Inc.
N. 116 West 18515, Moris Drive
Germantown, WI 53022 U.S.A.
Tel: (1) 800-272-3031 or (1) 262-255-6662
www.performancealloys.com

Figure 13
High-Conductivity Sprue Bushing

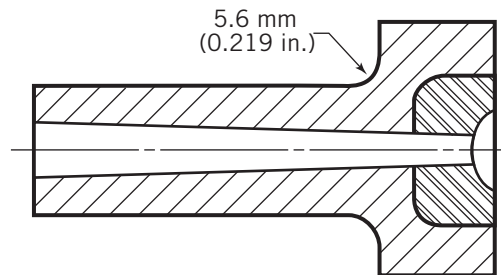

- Stainless steel nozzle seat
 - Wear resistant
 - Nozzle heat resistance
- Rigid sprues for pickers or grabbers
- Reduces cycle times
- Enhances release of molded parts

U.S. Patent 4,950,154

Mold/Sprue Cooling Example

Figure 14 shows a part with inadequate cooling. Notice the long sprue, with low draft and poor cooling. The part has poor cooling, and there is an air poppet valve under the sprue. This design resulted in extreme molding difficulties.

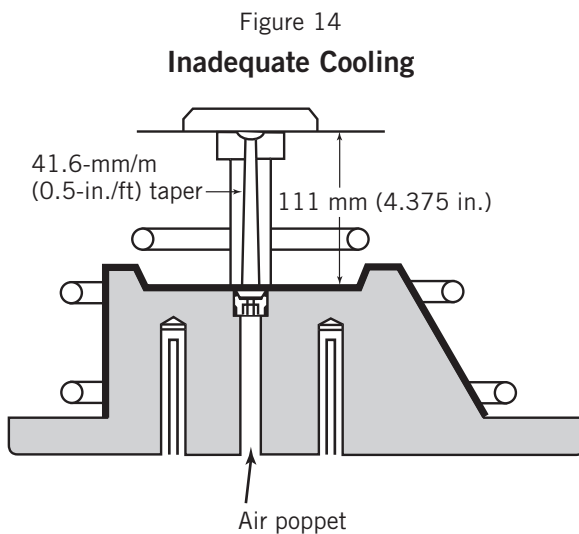
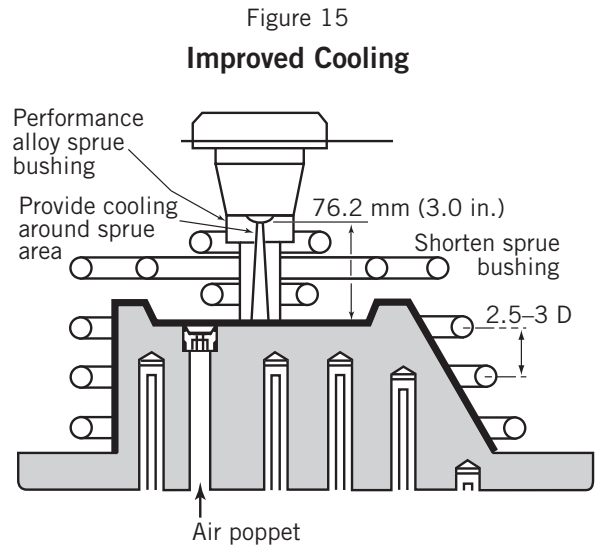

Figure 15 shows suggested modifications to the mold. The standard steel sprue bushing has been replaced with a shorter, performance alloy sprue bushing. There is better cooling around the sprue, and more cooling was added in the cavity and the core. The air poppet valve was moved away from the sprue. With these design modifications, the part was easily and successfully molded.



Hot Sprues

Hot sprues can be used for amorphous copolyesters and alloys. As with hot runners, the keys to proper design are low shear, good cooling at the part or sprue/runner end, uniform heating, and good temperature control.

Runner Design

When designing runner systems, use the same guidelines that apply to most engineering polymers. As shown in Figure 16, the runners should be designed for smooth, fully balanced flow. Generously radiused transitions reduce material hang-up and shearing. Cold slug wells are useful in trapping slugs of frozen material at the flow front. Vent the runners generously.

Figure 16

Typical Runner Layout

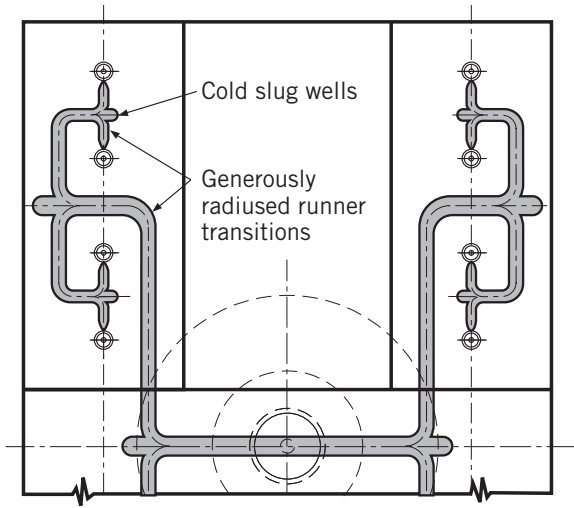

Runner Cross Section

Remember that flow efficiency in runners increases as the cross section approaches a circular shape. The most efficient runner is a round one, as shown in Figure 17. However, this requires machining both halves of the mold across the parting line. Typically, a compromise is reached with the half-round approach. Trapezoidal and rectangular runner systems are not optimum, as most of the flow takes place in the circular channels (dark shaded on the diagram), and the rest of the runner material is not used efficiently.

Figure 17

Runner Design Guidelines

- Flow efficiency increases as the cross section approaches a circular shape.

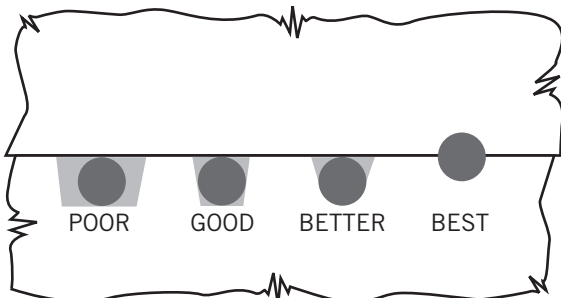

Half-Round Runner

For Eastman™ polymers, a 5° draft angle on the flat sides of the runner is recommended to ensure good ejection. The bottom of the runner should be fully radiused. See Figure 18.

Figure 18

Half-Round Runner Design

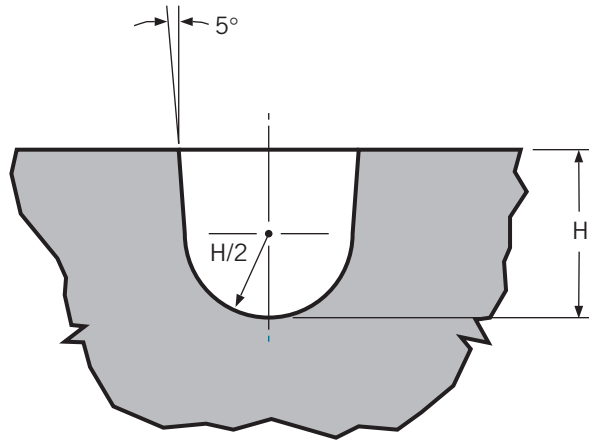

Gate Design

Eastman™ polymers can be molded using conventional gate design, including:

- Sprue gating (directly into part).
- Fan gates.
- Tunnel or submarine gates.
- Flash gates.
- Edge gates (tab or fan style).
- Hot runner systems.

The size and appearance of the finished part must be considered in selecting the type and location of gates.

Considerations for gate location(s) include:

- **Minimizing Flow Length**—Minimum flow lengths are typically made possible by locating the gate near the center of the mold. This minimizes pressure needed to fill the cavity, optimizes wall thickness necessary for easy molding, and reduces part cost.
- **Weld Line (Knit Line) Location**—Although Eastman™ polymers have relatively low-visibility weld lines, gate location does determine where weld lines will form. This should be considered in advance.
- **Minimizing Gate Blush**—Eastman™ polymers may have a small gate blush and can often be edge-gated into an appearance part with only a small transition distance. Gate design is a major factor in blush. Low-shear gates are essential.

Gate geometry is also very important to part appearance near the gate. Sharp corners or abrupt features in the gate or runner may need to be radiused to reduce blush. Gate thickness can also influence blush. Gate thicknesses less than 1.65 mm (0.065 in.) should be avoided.

NOTE: If Eastman™ polymers are molded in tooling designed for other materials, it may be advantageous to change the gate size to account for a different viscosity. In general, polyester-based materials may require larger gate sizes than some other polymers with lower viscosities. Typically, it is suggested that the gate be approximately 50%–80% of the wall thickness of the part.

It is good practice to gate into areas where the flow path is continuous and smooth, rather than

into notches or ribs. Streamlining the flow path helps maintain low shear. No sharp corners or sudden changes in thickness should be allowed. If a transition is needed from a thick sprue or runner to a thin wall, the change needs to be smoothly radiused over the available distance.

Avoid Gating Into Thin Sections

If it is necessary to make the wall thickness of a part nonuniform, gating should be into the thickest area. Gating into thin sections can cause:

- High material shear, which can cause degradation.
- Higher injection pressures during molding.
- Difficulty in filling thick sections.

Figure 19 shows a part that was improperly gated into a thin section. Whenever possible, parts should be designed with uniform wall thickness.

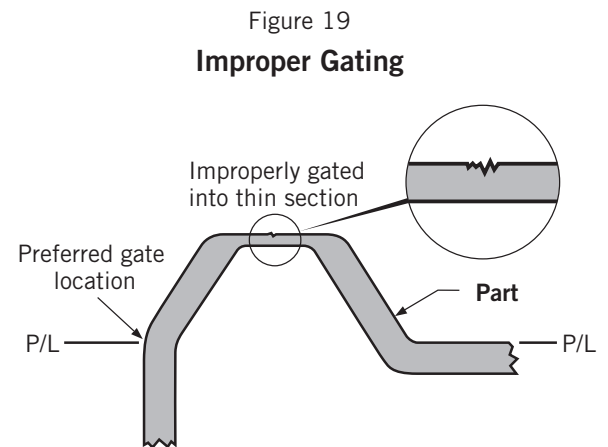

Tunnel Gate

Typical tunnel gate guidelines are generally applicable to Eastman™ polymers. In Figure 20, we suggest a maximum tunnel length of 50 mm (2 in.), at a 45° to 60° angle. A maximum gate land of 1.5 mm (0.060 in.) is suggested. The tunnel should have a taper of 5° to 20° to ease ejection.

Figure 20

Typical Tunnel Gate Design

- 50 mm (2 in.) length, maximum

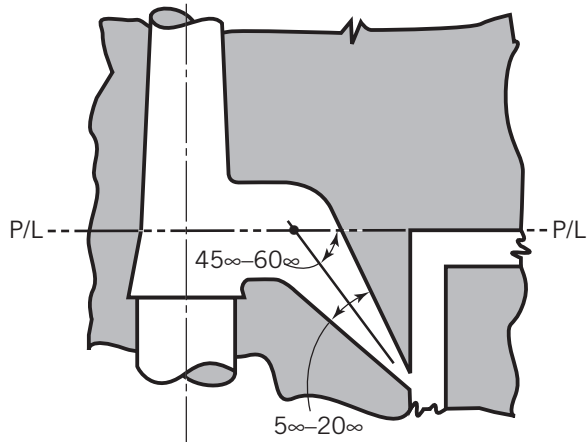

Fan Gate

One important consideration when designing fan gates is ensuring that the gate land has the proper length. If it is too long, a flow restriction that could lead to premature freezing of the gate is created. This could cause an underpacked part or a short shot: the material will take the shortest flow path through the gate and may not use the entire width of the gate effectively if the land is too long.

It is also important to maintain a constant cross-sectional area across the gate. Typically, a gradual taper through the thickness of the gate is used so that equal area is maintained at any cross section. To minimize shear, radius all corners. See Figure 21.

Figure 21

Fan Gate Design Guidelines

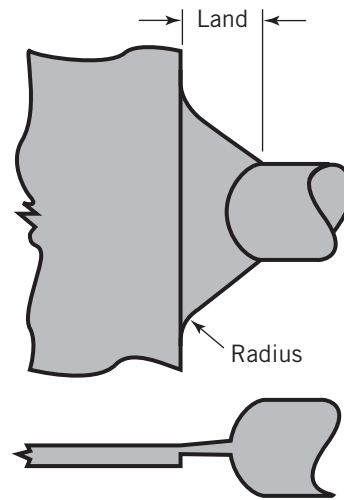

Edge Gate

A gate land of 1.0 to 1.5 mm (0.040 to 0.060 in.) is suggested. A generous radius at the edge of the gate will yield improved flow characteristics and reduce gate blushing. In general, the gate thickness should be 0.5 to 0.80 times the part thickness. See Figure 22.

Figure 22

Edge Gate Guidelines

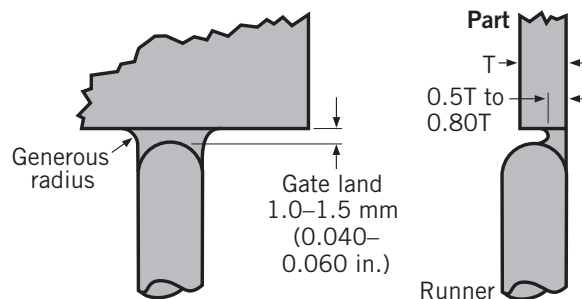

Edge Gating Into a Tab

Edge gating into a tab is an approach typically used on parts that require a good, cosmetic finish. The idea is for any blush or blemish to be confined to the tab. One disadvantage is that the tab must be removed in a secondary operation. To ensure a high-quality finish on the part, the thickness of the tab should be the same as the thickness of the part. See Figure 23.

Figure 23

Edge Gating Into a Tab

- Reduces blemish problems on part
- Tab must be cut away
- Tab thickness = Part thickness

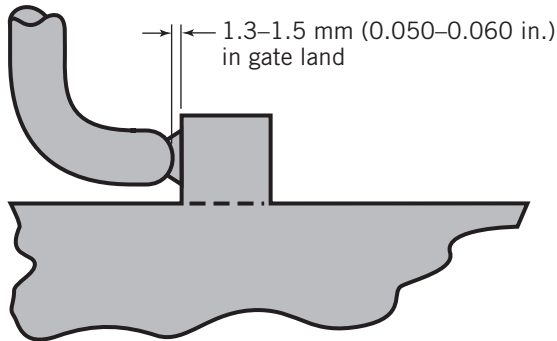

Gating Parts With Maximum Dimensions of 50 mm (2 in.) or Less

- Gate diameter 0.9 to 1.3 mm (0.035 to 0.050 in.) for most small parts.
- Gate into thick areas.
- Size gate according to part size.

Countersinking the gate area slightly helps prevent gate vestige or drooling from rising above the part. For example, gate vestige is undesirable in medical parts. A typical gate recess is 0.5 to 0.8 mm (0.020 to 0.030 in.). Modify the opposite wall geometry to maintain equal thickness, or high shear rates could develop at the gate during flow. See Figure 24.

Figure 24

Gating Small Parts

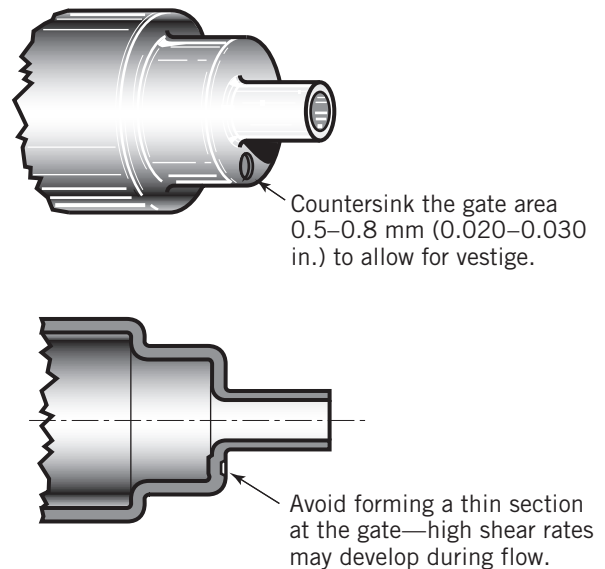

Hot Runner Systems

Design Guidelines

Hot runner systems are common in applications using polyester materials. When properly designed, these systems can eliminate sprue and runner regrind, mold with lower pressures, reduce cycle times, and improve processing windows. The selection of a suitable hot-runner system can vary greatly depending on the size of the part, polyester formulation, and part design. Therefore, it is critically important that runner design and selection be discussed jointly by the molder/end user, the tool builder, the hot-runner supplier, and Eastman to arrive at the appropriate runner-system design to be used.

Good hot runner systems will not have holdup spots in the manifold or gate areas. They will also be designed to avoid sharp corners, extremely small gates, and other high shear areas. In general, polyester materials are more shear- and heat-sensitive than many “commodity”

polymers. The system selected should be designed with that in mind.

Uniform Heating and Good Heat Control

Excellent thermal control and good cooling at the gate is critical for molding polyester materials. The mold should be designed so that heat is quickly removed from the gate. This is best accomplished by the gate orifice being an integral part of the cavity steel, rather than the hot-runner system being an insert projecting through the cavity into the part. When the gate is in the cavity, cooling channels (drilled water lines or annular-shaped passages) can be incorporated to provide the cooling needed for the cavity in the gate area. Some hot-runner suppliers offer gate-cooling inserts. Drooling, sticking, and stringing may occur if the gate does not cool properly. Steel that is directly heated as part of the hot drop should not contact the part directly; it should be insulated from the cooled portion of the mold.

We suggest separate cooling loops with individual flow and temperature control for hot drop gate cooling. The additional control is very useful in debugging and optimizing gate appearance and performance.

Eliminate Holdup Spots

The flow channel for the plastic should be streamlined and uninterrupted. Any crevice or pocket where material can collect and degrade will probably cause defective parts.

Minimize Shear Heating

The diameter of the flow path needs to be large enough to minimize the shear heating that can be caused by sharp corners or edges in the flow path at the gate or elsewhere. Mold filling analyses can show shear heating and indicate potential problems during the design stage.

Hot Drops

Externally Heated

Externally heated hot drops such as the one shown in Figure 25 are suggested for Eastman™ polymers.

Figure 25

Externally Heated Hot Drop

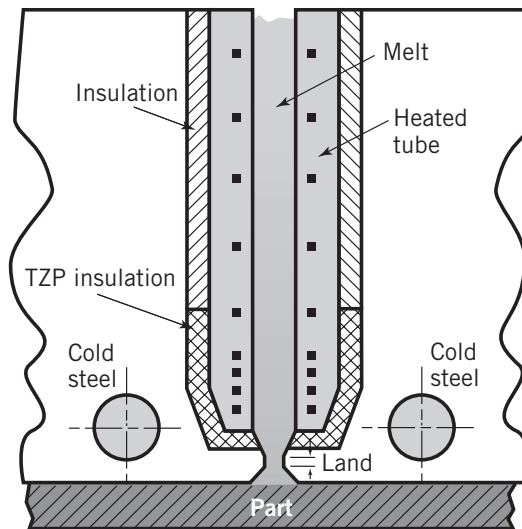

With this type of hot drop, the polymer is completely enclosed by a heated tube. All surfaces of the melt channel ID are maintained in the desired melt temperature. Heat flow from outside to the center results in a homogeneous melt temperature across the melt channel diameter. This allows for excellent temperature control, minimizing the potential for material degradation or crystallized material due to poor temperature control.

Excellent thermal control at the tip of the hot drop is critical to proper operation of this type of system. There is a relatively small distance between the bottom of the hot drop, maintained at the desired melt temperature, and the cavity surface, which must be cooled to the desired mold temperature. Heat transfer from the

heated drop to the surrounding mold steel is minimized with an insulated gap in the annular space between the hot drop and the mold steel. Some systems allow the molten polymer to flow into this gap and serve as the insulating material. This is not recommended with Eastman™ polymers, as this material can degrade and result in black specks or brown streaks in the molded parts. A more desirable solution is to use a high heat insulating material such as Vespel® to fill this gap. A cooling circuit or water jacket in close proximity to the gate is also required for heat removal. Plumbing this circuit independent from other cavity cooling channels can be beneficial, as separate water temperature control can be used to optimize molding performance in both the gate area and the mold cavity.

Many manufacturers offer different thermal tip styles for this type of hot drop system. In general, full flow open tip styles are suggested for most Eastman™ polymers. Styles such as a “spreader tip” design can be problematic with some of the faster crystallizing Eastman™ polymers. Consult with Eastman Design Services for thermal tip suggestions for specific material grades.

Internally heated probe type systems such as the one shown in Figure 26 are not suggested for Eastman™ polymers.

Figure 26

Internally Heated Probe Hot Drop

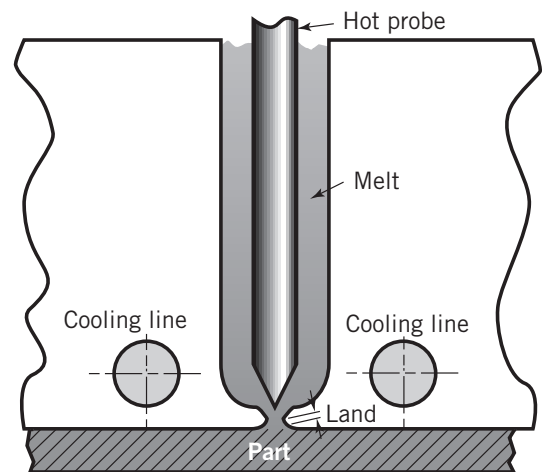

With this type of hot drop, the polymer flows down the annular space between the OD of the heater probe and the ID of the melt channel. Heat generated from the internal probe moves out from the probe into the melt. A thin layer of polymer freezes on the colder steel on the melt channel ID. Higher probe temperature setpoints are often required to keep the melt channel from freezing completely. The combination of the frozen layer and higher temperature setpoints can lead to material degradation and difficulty maintaining consistent processing condition setpoints. Degraded material often results in black specks or brown streaks in the molded parts with this type of system.

Valve Gates

If possible, a valve system should be used when processing Eastman™ polymers (see Figure 27). This has several advantages when compared to other hot melt delivery systems. With valve gates the melt channel is externally heated and the mechanical shutoff feature allows better gate vestige control. The gate size is generally larger when compared to other available systems. The valve pin is retracted during the filling process and a less obstructed flow and the end result is less shear heating and pressure drop.

Figure 27
Valve Gate

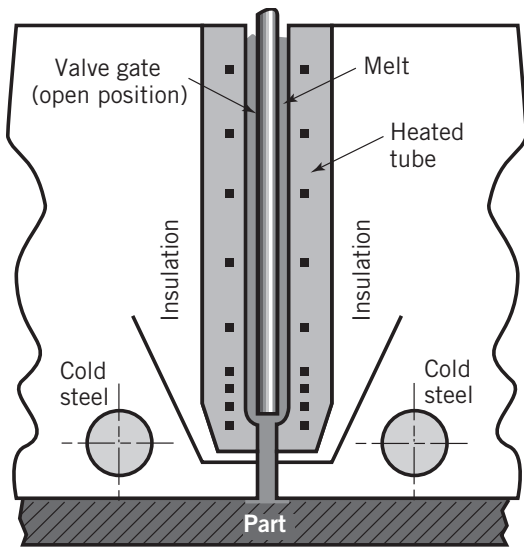

It is important to maintain suggested tool temperatures at the interface with the part. An independent cooling circuit in close proximity as shown is always suggested. Another viable solution for temperature control is a water jacketed insert. These are sometimes custom fabricated but are also available as standard items from some of the manufacturers. These usually result in a witness around the gate which may need to be taken into consideration.

Special care should also be taken to ensure the valve pin seats well to insure good contact. Even with adequate cooling and good contact there are limitations with gate size. Gate sizes 3.00 mm and below generally result in the best aesthetics. Gates larger than this are often difficult to cool and result in poor gate aesthetics due to sticking. Another factor affecting gate area aesthetics is crystallization. The degree of crystallization will vary with the material's propensity to crystallize, and an Eastman technical service representative should be consulted to determine whether or not this will be an issue with your particular material candidate.

Careful consideration to the amount of insulation used at the drop from the mold is still needed with valve gates. Vespel® insulators have also been suggested for these gates.

Processing Conditions Using Hot Runner Systems

In general, manifold and drop temperatures should be set near the actual on-cycle melt temperature value. The manifold and drops should be balanced for uniform flow. Many molders use hot drops to gate into a small, cold subrunner. This allows the benefits of cold runner gates while reducing regrind or scrap.

Some polyester materials such as PET tend to crystallize and whiten at the gates. Thus, it is often beneficial to gate into noncritical areas or to gate into a post or tab that can be hidden or removed. Consult your Eastman Technical Representative and hot runner supplier for more detailed information on gate placement, gate size, and other hot runner system details.

Venting and Ejection

Venting allows gas replaced by the melt front to escape from the mold. Short shots, burning, and material degradation can occur if parts are not adequately vented. To prevent this:

- Provide adequate venting in the proper location.
- Check and clean vents regularly.
- Use ejector pins as vents where possible.
- Avoid vents that require mold disassembly for maintenance access.

Typical Venting in Molds Designed for Eastman™ Polymers

Figure 28 illustrates a vent layout for a mold running Eastman™ polymers. A good starting vent depth for molds designed to run Eastman™ polymers is 0.012 to 0.025 mm (0.0005 to 0.001 in.) for small parts or vents close to the gates and 0.025 to 0.038 mm (0.001 to 0.0015 in.) for larger parts. A typical land is 3 to 6 mm (0.125 to 0.250 in.) long, opening up into a larger channel that allows gas to vent from the mold.

Figure 28
Vent Layout

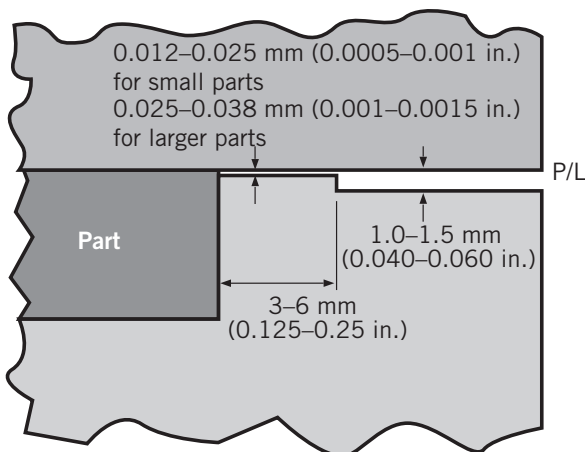

Venting problems can also be attributed to improper location of vents. Venting problems can sometimes be solved by relocating the gate so that the last area to fill is shifted to an area that has better venting.

Ejection Systems in Molds Designed for Eastman™ Polymers

In general, Eastman™ polymers can run in molds designed for other polymers without the need for additional ejection. As with any other polymer, use plenty of ejector pins or ejection sleeves where practical. Inadequate ejection can cause part distortion.

Because polyester materials tend to stick to hot [$>50^{\circ}$ to 65° C (120° to 150° F)] mold surfaces, generous cooling will greatly ease ejection.

Be sure to include enough “daylight” in the tool to eject the part without hanging or scuffing.

A smooth, polished mold surface makes the part easier to eject. However, overpolishing the surface can result in a vacuum being drawn during ejection.

Alloys for Mold Construction

There are several factors to consider when selecting steel for the mold:

- Wear resistance.
- Toughness.
- Machinability.
- Polishability.
- Dimensional stability.

The steels most often used are P20, H13, and S7.

Core and Cavity Steels. P20 steel is supplied prehardened at a Rockwell hardness (R_c) of 30 to 32, which eliminates the need for heat treatment. P20 will polish to a very high finish, but rust-preventive greases will be required during shutdowns to preserve the finish; otherwise, plating will be necessary. Plating can be an impediment during repairs. The thermal conductivity of P20 is better than that of H13, 420, and S7, but its conductivity could eventually be impeded by cooling channel corrosion. P20 costs less than H13 and 420.

H13 steel typically requires heat treatment for more hardness and durability. H13 has less toughness and thermal conductivity but higher wear resistance than P20. Because of its higher hardness, parting lines in H13 hold up longer than those of P20. With reduced thermal conductivity, increased cooling should be considered. H13 can also rust if not properly protected during use.

Although 420 stainless steel has lower thermal conductivity than H13, it offers rust resistance on the polished surface and cooling channels that is not available with P20 or H13. Heat treatment similar to that of H13 is required for 420SS. Some suppliers also have a 414SS prehardened the same as P20, at an R_c of 30 to 32, which eliminates the need for heat treatment.

Slides and Lifters. S7 tool steel is often used for hardened slides and lifters. Wear plates and gibs are often constructed from O1, O6, and A10. Bronze or bronze-coated (Lamina® bronze) plates are also used adjacent to sliding surfaces.

Inserts. Eastman often suggests utilizing inserts in areas that may be difficult to cool such as

tall, relatively thin standing core details. Two common thermally efficient alloy families utilized for this are Moldmax® and Ampcoloy®. Special care should be taken to ensure the inserts have proper cooling. Relieving of the insert for ease of assembly should be minimized to eliminate the formation of insulating air-gaps. In addition, a cooling line in close proximity is crucial when relying on cooling from the main tool body. In extreme cases, the inserts should be designed with integral cooling passages to ensure proper heat removal.

Because processability is dependent on the mold, it is necessary to consider material options and toolmaker recommendations carefully. Mold investments will pay huge dividends in production.

Family Molds

Family molds contain two or more cavities that mold different parts. Eastman™ polymers are being used successfully in family molds. Like any other polymer, their flow into the individual parts must be balanced. All parts should fill evenly and equally. Otherwise, uneven packing will occur; some parts will be overpacked and highly stressed, leading to warpage, and other parts will be underpacked or not completely filled.

Note: Family molds should be avoided if possible because balanced flow is difficult to achieve. If family molds are required, flow should be balanced by varying runner diameters, not gate size.

Mold Polishing and Texturing

Mold Polishing

Eastman™ polymers provide excellent gloss and pick up mold finish very well. Keep in mind that surfaces polished smoother than required for ejection only add to mold cost. In most cases, highly polished surfaces can hinder ejection if there is a vacuum drawn in low or no draft areas. Where no vacuum is drawn, polished surfaces generally eject better.

The following guidelines are suggested:

- Specify SPI mold finish standards.
- Specify surfaces smooth enough to minimize ejection force.
- Specify final polish in the direction of draw to minimize scuffing.
- Add a light 320 dry grit blasting (SPI B3 finish) to drafted walls to reduce the possibility of a vacuum forming during ejection.

Texturing Mold Surfaces

Texturing is useful in hiding weld lines, flow marks, gate blush, sink marks, and scuffing. There are hundreds of standard patterns available. Basically, anything that can be drawn in black and white can be used as the basis for a texture pattern.

It is important to decide on a texture pattern early in the design process so that the proper draft angles and contours can be incorporated into the part.

Typical texture depth is 0.06 to 0.08 mm (0.0025 to 0.0030 in.). To aid ejection, 1° to 1.5° of draft should be added for each 0.025 mm (0.001 in.) of texture depth.

Texturing Methods

There are many different methods for applying textured surfaces:

- Mold Polishing—User controls degree of gloss by varying polishing grit diameter.
- Photoetching—Most common texturing procedure.
- Electric Discharge Machining (EDM) or Spark Erosion—Makes economic sense if the cavity of the tool is eroded by EDM also.
- Sandblasting—Suitable only for mostly flat surfaces.
- Matte Chromium Plating—Produces a matte, wear-resistant texture.

Preventing Surface Defects

Careful consideration should be given to the part design if a surface finish is expected on the final product. Abrupt changes in wall thickness, relatively thick sections, or heavy ribs can cause variations in surface gloss. Uniform mold temperatures are needed to ensure that the texture is even throughout the pattern.

To achieve a higher matte finish, double or triple the texture etching.

If weld lines are visible on the final product, one alternative is to move the gate positions so that the weld line is formed in a less visible place. If this is not possible, apply a rounded texture pattern to help hide the blemish.

If the material you are molding is expected to have poor scratch resistance, use a rounded texture pattern to hide potential marks.

Draft Angle Guidelines

In most cases, 1° draft per side is suggested to aid ejection. However, ½° per side can be used to obtain reasonable dimensions in ribs, bosses, and other design features. Attention to the thickness at the top of ribs or bosses is needed to ensure structural strength.

Using Zero Draft

Zero draft is not recommended. It can cause the mold to lock up during ejection. It can also increase the cost of the mold significantly because of the additional mechanisms required for ejection.

If zero draft is necessary, it can be more easily accomplished in cases where the cores are short, the parts are thick so that the walls will not tend to shrink tightly to the core, or sleeve ejectors are used. Sometimes side pulls can be used on the outside of a cylindrical part so that low draft on the inside core can be easier to release.

Other areas to consider:

- Provide excellent core cooling to prevent the polymer from sticking to the hot mold surface.
- Polish the core in the direction of draw to aid ejection.
- Add air poppet valves to break the vacuum in areas with deep draw.

Zero draft is a critical issue. It is wise to discuss the need for zero draft with your toolmaker or molder.

Undercuts

Stripped undercuts such as “rice grains,” snap rings, or threads are allowable up to 2%–3% of the part diameter in relatively thin-walled parts.

Undercuts must be rounded and well filleted to allow proper ejection.

Mold Surface Treatment to Aid Ejection

In some cases, a low draft angle may be required on a part but the dimensions of the mold may not be suitable for proper cooling. Surface coatings or treatments that can aid in the ejection of parts are available. We have completed an extensive study to determine which coatings and treatments are better release agents for our polyesters. The top three that we suggest follow.

Poly-Ond® Coating

This coating is designed to reduce the coefficient of friction of the tool surface. It is made of a nickel phosphorous alloy deposition with polytetrafluoroethylene (PTFE or Teflon® coating). PTFE is sprayed or dipped onto a micro-fractured plated surface. As the outer layer wears, the PTFE captured in the fracture pores will continue to provide lubricity.

The coating thickness is typically 0.008 to 0.013 mm (0.0003 to 0.0005 in.) of nickel and 0.013 to 0.018 mm (0.0005 to 0.0007 in.) of PTFE. The hardness is 50 Rockwell C (R_c) as applied and can be heat treated to 68 R_c. The continuous operation temperature range is –55° to 260°C (–65° to 500°F).

Poly-Ond® coating is provided by:

Poly Plating, Inc.

2096 Westover Road

Chicopee, MA 01020-0135 U.S.A.

Tel: (1) 800-256-7659 or (1) 413-593-5477

www.poly-ond.com

Tungsten® Disulfide Coatings

These coatings have more lubricity than any other dry substance known. They are applied with pressurized air at ambient temperatures. Upon application, the steel appears blue-gray. When this color disappears, the coating should be reapplied. They can be applied to an SPI A1 diamond finish.

The dynamic coefficient of friction is 0.03 against itself. It is a very thin coating, typically 0.5 microns, or 20 millionths of an inch. The hardness is 30 R_c.

We suggest Diconite® DL-5 from:

Diconite Dry Lube of New Jersey
121 North Michigan Avenue
Kenilworth, NJ 07033 U.S.A.
Telephone: (1) 800-605-8222
www.diconite.com

WS2™ from:

Micro Surface Corporation
465 East Briscoe Drive
Morris, IL 60450 U.S.A.
Telephone: (1) 800-248-4221 or
(1) 815-942-4221
www.microsurfacecorp.com

Nicklon® Coating

This alloy is 10.5% phosphorous-dissolved nickel with 25% PTFE suspended in solution. It is applied using electroless codeposition. As the coating wears down, new PTFE particles are continuously introduced to the mold surface, maintaining lubricity over a long period of time.

The coating is known to improve chemical resistance of the steel surface. However, because of the slightly porous nature of the codeposition, in extremely harsh environments the coating can be chemically stripped. In this case, an electroless nickel pretreatment of the steel should be considered.

The dynamic coefficient of friction is 0.03 against itself. The typical thickness is 0.008 to 0.013 mm (0.0003 to 0.0005 in.). The hardness is 48 R_c as applied and can be heat-treated to 70 R_c. As for wear resistance, it is equal to hard chrome after heat treatment.

Nicklon® coating is provided by:

Micro Surface Corporation
465 East Briscoe Drive
Morris, IL 60450 U.S.A.
Telephone: (1) 800-248-4221 or
(1) 815-942-4221
www.microsurfacecorp.com

Bales Mold Service, Inc.
2824 Hitchcock Avenue
Downers Grove, IL 60515 U.S.A.
Telephone: (1) 630-852-4665
www.balesmold.com

Part II Processing

Choosing the Molding Machine

Some of the parameters to consider in choosing a machine for molding Eastman™ polymers are:

- Machine capacity (weight of shot).
- Clamping force available.
- Ability to profile injection speed.

A discussion of these and other factors follows.

Machine Size

Selecting a machine with shot capacity about twice the expected shot size usually allows a good operating window. It is important to include adjustment for specific gravity of the material when the part weight is determined. Operating at approximately 10% of machine capacity causes long holdup time of melt in the barrel and contributes to degradation; approaching the 80% to 90% end of the scale makes it more difficult to maintain consistent melt quality and shot-to-shot uniformity. See the section on “Molding Conditions—Barrel and Melt Temperatures” (page 32) for suggestions on how to compensate for using high or low percentages of shot capacity. When operating near the low end of the scale (small shot in a large machine), it is important to run as short a cycle as possible to minimize holdup time.

Experience shows that excessive holdup time caused by an oversized barrel is the second leading cause of degradation in copolyesters (lack of drying is first). Degradation can be quantified by checking the I_h.V. (inherent viscosity) or by gel permeation chromatography (GPC), which identifies molecular weight. The GPC test will measure molecular weight directly while the I_h.V. test will measure solution

viscosity, providing a relative indicator of physical property retention.

Clamping Force

Required clamping pressure can be calculated from a mold filling analysis where wall thickness, flow length, specific material, melt temperature, and mold temperature are taken into consideration. Clamp tonnage (maximum clamping pressure available) is typically 40 to 70 MPa (3 to 5 ton/sq in.).

Total clamping force needed may also be calculated by multiplying the part's projected area on the platen of the molding machine by 40 to 70 MPa (3 to 5 ton/sq in.).

Injection Speed

Capability to profile injection speed is another important factor in choosing a machine. The ability to change the speed smoothly as the screw moves forward can make molding much easier and the processing window wider, especially in larger parts.

Screw and Barrel Design

General-purpose screws (Figure 29) with compression ratios of approximately 3.0 to 1 and L/D ratios of 18:1 to 20:1 have been used successfully. Screw flight depths are also important. Suggested flight depths can be obtained by discussing your application with an Eastman technical service representative. The transitional zone should be gradual, typically 4 to 7 diameters, so that high-shear heating of a sudden transition is avoided. These polymers generally cause little wear on the screw and barrel; therefore, corrosion of the barrel and screw components is not expected.

Figure 29

Injection Screw Features and Terminology

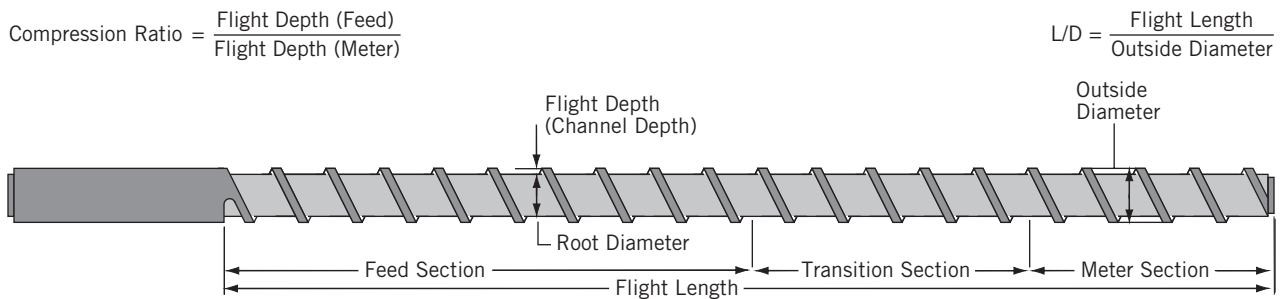

While vented barrels have been used with limited success, they are not a substitute for proper drying. In addition, the vent should be kept clean when processing clear material. Volatiles from polymers can accumulate and carbonize in the vent; this can cause the polymer being processed to be contaminated with black specks. The middle decompression area on the vented screw typically causes screw recovery to be sacrificed unless faster screw speeds are used; however, faster screw speeds will likely result in increased shear heating.

Ring-check (nonreturn) valves are generally preferred to ball-check valves, although ball-check valves have been used successfully. Ball-check valves must be carefully designed to allow free passage of material with an absolute minimum holdup. The area of flow-through should have approximately the same cross-sectional area for melt flow as the metering section of the screw. Check rings need to be replaced periodically, as they can wear and sometimes even break. Wear could be indicated when the screw will not hold a cushion and continues to move forward after the shot and packing are complete. In extreme cases, frequent short shots will result.

Nozzles

Select nozzles with the minimum length needed to extend into the mold. General-purpose nozzles of uniform bore or larger-diameter nozzles that use generous radii to gently reduce diameters at the exit end are preferred. The inside diameter of the nozzle should be very close to that of the sprue end, but just slightly smaller so that the sprue can be pulled. Nozzles with inside diameters of 5 to 8 mm ($\frac{3}{16}$ to $\frac{5}{16}$ in.) are typical for smaller parts; those for larger parts should have a 9.5-mm ($\frac{3}{8}$ -in.) or larger diameter.

Good temperature control of the nozzle is important. If a thermocouple at the threaded end of a long nozzle is controlling a heater band or bands at the other end, temperatures at the heater band end can be more than 55°C (100°F) higher than the thermocouple is able to sense. This can be checked by inserting a needle pyrometer to different depths in the nozzle opening. The remedy is to either reduce the set point of the controller or, preferably, to use a nozzle fitted with a thermocouple in the center of its length with heater bands located uniformly on both sides, as shown in Figure 30.

Long nozzles may require more than one thermocouple/controller/heater band along their

Figure 30
Injection Nozzle

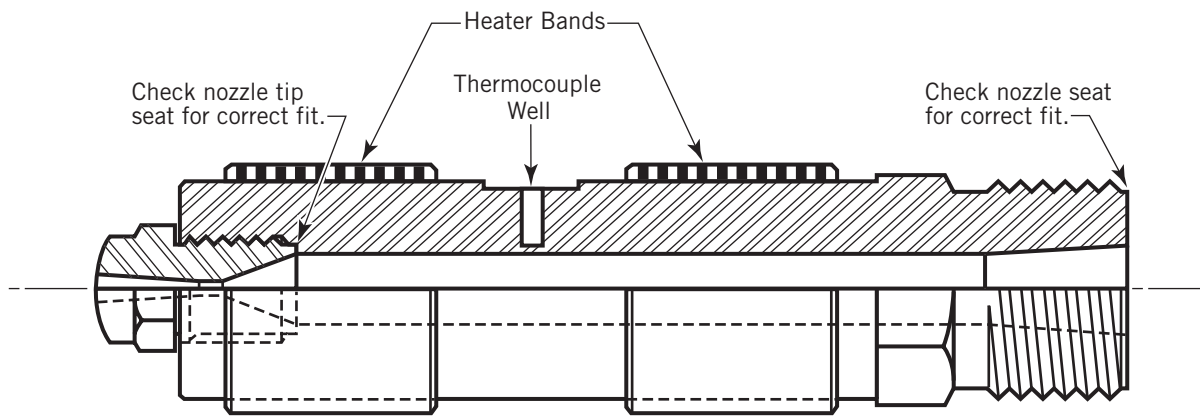

Nylon Configuration Suggested for Copolyester

length for uniform heating. Nozzles with gas-charged heat pipes have been used successfully to heat the full length of long nozzles more evenly. Temperature control problems in the nozzle show up as appearance problems at or near the gate. Nozzles with a removable tip require special attention to verify that the tip bottoms out on the shoulder below to prevent a dead space where polymer can degrade; if this happens, black specks can form and reenter the melt stream.

Periodic Inspection

The screw, check valve, and nozzle assembly should be taken apart, cleaned, and inspected periodically to measure wear and to look for cracks or any other spots where material can collect and degrade. Small cracks or unseated threads can be big enough to cause streaking or degradation.

Drying

Drying is an absolute necessity to prepare polymers for molding.

All polymers readily absorb moisture. Desiccant dryers must be used to dry the pellets prior to processing in the injection molding machine. A typical desiccant dryer is shown in Figure 31.

If pellets are not dried, the moisture will react with the molten polymer at processing temperatures, resulting in a loss of molecular weight. This loss leads to lowered physical properties such as reduced tensile and impact strengths.

Molded parts may not show any noticeable defects such as splay but may still exhibit lower physical properties

Equipment

Multibed desiccant dryers. These dryers have two or more desiccant beds and are recommended to properly dry the polymer. Dryers having three or four beds typically have shorter start-up times because of quicker bed regeneration. Desiccant dryers are available from many suppliers. Work with your desiccant dryer vendor to select the optimum dryer for the molding job. Locating the drying hopper on the feed throat of the molding machine is preferred. Planning should include

Figure 31
Typical Desiccant Dryer

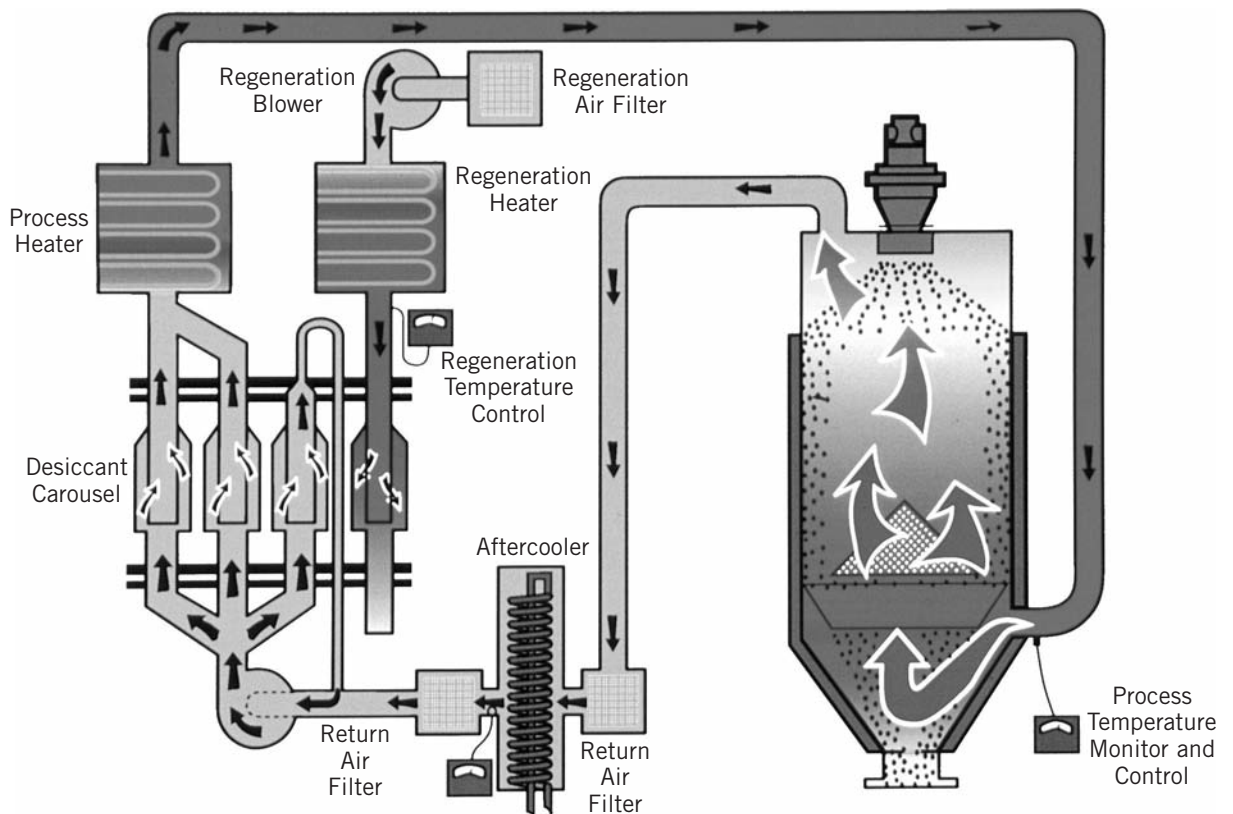

consideration for throughput rate, ease of maintenance, reliability, and low variability of the four elements necessary for proper drying (drying temperature, drying time, dryness of air, and airflow, which are discussed in the section, “Elements Necessary for Proper Drying” on this page).

Tray Dryers. These dryers can be used only if they are supplied with air dried by a good desiccant bed system. Tray dryers with heating only (and no desiccant) do not adequately dry the pellets. Good dryers for production typically include either rotating beds or other means to keep continuous airflow through a freshly regenerated bed while other beds are regenerated off-line. Tray dryers with manually charged single beds are also generally not recommended for continuous production operations.

Conditions

The recommended drying time and temperature are listed on the data sheet for each Eastman™ polymer.

Elements Necessary for Proper Drying

Drying Temperature. Air circulating through the hopper is heated by the process heater or afterheater. The *air temperature should be measured at the inlet to the hopper* and controlled at the recommended drying temperature for a given polymer. Exceeding this temperature will cause premature softening or melting of pellets to the point of sticking together, causing failure to feed freely to the bottom of the dryer for unloading. Drying at temperatures below the recommended set point will result in inadequate drying. When the

controlling thermocouple is located away from the hopper, the set point may need to be raised to offset heat loss from the air during transport to maintain the desired hopper inlet temperature. Check the temperature over *several cycles* of the process heater. If the actual temperature overshoots the set point, adjust the set point accordingly to avoid overriding temperatures. Drying temperature should be held constant within $\pm 3^{\circ}\text{C}$ ($\pm 5^{\circ}\text{F}$). Insulated supply hoses and hoppers make drying much more effective and save energy costs.

It is also important to maintain air temperature [at least 205°C (400°F)] in the regeneration loop of the dryer. The regeneration loop is a separate system from the process loop, so the presence of hot air in the process loop does not guarantee that the regeneration loop is functioning.

Drying Time. Pellets to be dried need to be in the hopper at the conditions shown on the data sheets for each specific polymer. If the dryer is turned on from a cold start, it must warm up to the proper temperature and the dew point of the air must be reduced to -30°C (-20°F) or below before drying time can be counted.

Choosing the hopper size is critical; only when the hopper size is adequate for the rate of processing will the proper residence time in the hopper be possible. For example, if a 454-g (1-lb) part is being run on a 1-minute cycle, then 27.2 kg (60 lb) of dry material will be needed each hour. If 6 hours is required for drying, then at least 164 kg (360 lb) of material must be in the hopper continuously [$27.2 \text{ kg/h} \times 6 \text{ h}$]. The hopper should be built so that plastic pellets in all parts of the hopper will move uniformly downward as material is

removed from the bottom. Funneling of pellets down the center of the hopper while pellets near the outside move more slowly will result in inadequate drying.

In routine operation, drying time is maintained by keeping the hopper full. If the hopper level is allowed to run low, residence time of the plastic in the hopper will be too short and the material will not be adequately dried. For this reason, and to compensate for less-than-perfect plug flow through the dryer, the hopper should be larger than the exact size calculated.

Dryness of Air. Dry air comes from the desiccant beds in the closed air circulation loop of the dryer/hopper system. Desiccant beds must be heated and regenerated before they can dry incoming process air. After regeneration, it is beneficial to cool down the regenerated bed with closed loop (previously dried) air as opposed to ambient air.

Returning process air from the top of the pellet hopper is filtered before it is blown through the desiccant bed and on to the heater and hopper. Dryers used for polyesters should be equipped with aftercoolers to cool the returning process air. Air temperature should be below 65°C (150°F) to increase the desiccant's affinity for moisture, thus improving efficiency.

The desiccant in the beds is typically a very fine claylike material in pea-size pellets. It slowly loses its usefulness and must be replaced periodically—usually about once a year. Use of plastic with a high dust content (such as regrind) or materials containing certain additives will reduce the life of the desiccant by coating the pellets or saturating them with a nonvolatile material. Good filters can help extend the life of the bed and the heater elements.

Air dryness can be checked by dew point meters, either portable or installed in-line in the dryer. Built-in dew point meters and alarms are the wise choice for polyesters. These meters give a direct reading of the dew point of the air tested. When the dryer has rotating beds, the meter must run long enough for all beds to be checked. Each bed can normally be on-line for 20 to 40 minutes or longer; a new bed should rotate into position before the dew point rises above -30°C (-20°F). (Also see the discussion on “Moisture Measurement on this page”).

Note: Once pellets are dried, they must not be exposed to moist air in conveying or at the machine hopper. Otherwise, the pellets may reabsorb enough moisture to cause splay or lower physical properties.

Airflow. The usual airflow rate requirement for drying is 0.06 cubic meter of hot dry air per minute for each kilogram of material processed per hour ($0.06\text{ m}^3/\text{min}$ per kg/h) or 1 cubic foot of hot dry air per minute for each pound of material processed per hour (1 cfm per lb/h). For example, if 109 kg (240 lb) of material is used per hour, airflow should be at least $6.7\text{ m}^3/\text{min}$ (240 cfm). Minimum airflow to ensure good air distribution is usually about $2.8\text{ m}^3/\text{min}$ (100 cfm) for smaller dryers.

Airflow can be checked by in-line airflow meters, by portable meters, or much less accurately by disconnecting a hose going into the hopper and feeling the airflow—basically a yes/no on airflow.

If there are dust filters in the circulation loop, these should be cleaned or replaced periodically to avoid reduction in the airflow rate.

Moisture Measurement

Dew point meters measure only the dryness of the air, not the dryness of the plastic pellets in the hopper. Use of the dew point meter along with measurements of temperature, airflow, and time can give an accurate indication of whether the plastic pellets are being dried properly.

Weight loss type moisture meters are instruments that measure the moisture inside pellets. These meters can give a general indication of the effectiveness of the drying system in reducing the moisture level in the plastic pellets. However, most are usually not accurate enough to use as a quality control method to ensure adequate dryness of polyesters to prevent degradation during processing. A moisture level in the range of 0.005% to 0.015% is desired, and this is determined using analytical means other than the preceding.

Dryer Troubleshooting

Dryers require routine checking and maintenance.

A good mechanic that understands dryers and has the time and support to maintain them is needed. The following information is provided to help give that understanding. Dryer suppliers can help also.

Common Dryer Problems

- Poor airflow caused by clogged filters.
- Air passing through the middle of the load rather than dispersing through the pellets caused by unfilled hopper.
- Supply/return dry air lines allowing ambient “wet” air to contaminate dry air.
- “Wet” air contamination through loader on top of hopper.
- Lack of cooldown on air returning to the bed in absorption process. Air should be cooled below 65°C (150°F) to increase the desiccant’s affinity for moisture, thus improving efficiency. An aftercooler is required when drying some polymers.
- Reduced desiccant effectiveness caused by worn-out or contaminated desiccant.
- Nonfunctioning regeneration heater and/or process heater.
- Blower motor turning backwards.
- Airflow not being shifted when controls call for bed change; one bed stays in process continuously.

Dryer Troubleshooting Guide

For more detailed information, see the “Troubleshooting Guide” on page 40.

Problem	Possible Cause	Corrective Action
High Dew Point (Wet Air)	Desiccant worn out or saturated.	Dry cycle machine or replace desiccant.
	Incorrect desiccant type.	Replace desiccant with type and size recommended by dryer manufacturer.
	Regeneration heaters burned out.	Replace heaters.
	Regeneration filter plugged.	Clean or replace filter.
	Regeneration blower reversed.	Reverse electrical connections.
	Air leaks.	Check and repair auto loader seal and/or hoses to hopper.
	Beds not changing at the proper time.	Reset or repair controller.
Low Airflow	Return air too hot.	Add or repair aftercooler.
	Dirty air filter.	Clean or replace filter.
	Fan motor reversed.	Reverse electrical connections.
	Hoses reversed between inlet and outlet.	Connect dryer outlet to inlet at the bottom of the hopper.
	No hose clamps. Hose disconnected.	Connect and clamp hoses.
Short Residence Time	Hose smashed or cut.	Repair or replace hose.
	Hopper too small.	Use larger hopper.
	Hopper not full.	Keep hopper full.
Temperature High or Low [or Varying More Than ~3°C (~5°F)]	Tunneling or “rat holes.”	Remove clumped material or install proper spreader cones.
	Incorrect temperature setting.	Set correct temperature.
	Temperature controller malfunction.	Calibrate or replace temperature controller.
	Dryer not designed to maintain correct range.	Repair or replace dryer.
	Thermocouple loose or malfunction.	Repair or replace thermocouple.
Heater malfunction.	Repair or replace heater.	

Injection Molding

Proper conditions and machine operations for molding Eastman™ polymers are discussed in this section. It includes sections on start-up, purging, use of regrind, and shutdown. The recommended processing conditions are listed on the technical data sheet for specific Eastman™ polymer grades. These data sheets can be found online at www.eastman.com.

Molding Conditions

Barrel and Melt Temperatures

The first consideration in setting barrel temperatures is how much shot capacity will be used. Typically, if about half the machine's shot capacity is used in each shot, barrel temperatures are set almost the same from back to front or slightly cooler at the feed end. If the shot is small relative to machine capacity, then temperatures are set significantly cooler at the feed end to minimize degradation due to long residence times at high temperatures. If the shot size is most of the machine's capacity, then flat or higher temperatures at the feed end are typically used. These polymers often require a descending profile with higher rear-zone set points to achieve proper screw recovery.

Another important factor is expected cycle time. For example, if the expected cycle time is long because of limited mold cooling, barrel temperatures should be lower. Different screws add different amounts of shear heat, but it is common to see melt temperatures 10°–20°C (20°–40°F) above the barrel settings.

Actual melt temperature should be checked with a needle pyrometer. Melt temperature is best taken when the cycle is established, and an on-cycle shot is caught in an insulated container.

(CAUTION: Care must be exercised when taking samples of HOT molten material.)

Melt temperature is the biggest factor in ease of filling the mold. Typically, melt temperatures 5°–20°C (10°–30°F) above the minimum temperature required to fill a part will give a good processing window. Melt temperatures on the high end tend to cause degradation and related problems.

Mold Temperatures

Mold temperatures affect overall cycle, shrinkage, warpage, and other characteristics of the molded part.

Amorphous copolyesters and alloys require colder molds than some other plastics; therefore, anticipating cooling needs ahead of time (i.e., via tool design) pays dividends in reduced cycle time and processability.

High mold temperatures can cause sticking. Even localized hot spots where sticking might occur can extend the cycle.

Injection Speed

To minimize gate blush, splay, or both, the fill speed used for amorphous copolyesters and alloys is slower than for some other plastics. Machines with fill speed programming capability are recommended. Start the fill at a very slow speed, such as 10% to 20% of available capacity for the first 3% to 15% of the shot, then increase to 40% to 60% to complete the shot. An average fill rate of 50 to 250 g/sec (1.76 to 8.8 oz/s) is typical.

Screw Speed

The screw should be run at the minimum rpm that will allow it to recover 2 to 5 seconds before the mold opens. This minimizes viscous heat generation, tends to make the melt more uniform, and minimizes dead time.

Pack and Hold

A common problem with direct sprue-gated parts is a shrinkage void at the base of the sprue. Long hold times of 8 to 12 seconds and lower hold pressures of 275 to 550 bar (4,000 to 8,000 psi) (nozzle plastic pressure) will feed material to the sprue at a rate that will eliminate voids but not overpack the sprue. Overall cycle time does not have to be extended if the cooling timer is decreased by the amount the hold timer is raised. A shrinkage void can also form with a conventional runner at the junction of the runner and sucker pin; this can be eliminated by using the above methodology.

Cushion Size

Cushion size should only be large enough to ensure the screw does not hit bottom and the pack-and-hold pressures are transmitted to the part. The cushion left at the end of the pack-and-hold phase of the cycle is typically 3 to 13 mm (0.125 to 0.5 in.), depending on machine size and injection speed. Larger cushions can increase holdup time in the barrel and contribute to degradation. Continued forward movement of the screw at the end of the shot indicates a leaking check valve. A leaking check valve will prevent a cushion from being maintained and can cause random short shots and shot-to-shot variability.

Back Pressure

Typical back pressure is 7 to 10 bar (100 to 150 psi), though it may be as low as 3.5 bar (50 psi). To improve melt uniformity, increase melt temperature, or eliminate air entrapment (air splay), back pressure can be increased to as much as 28 bar (400 psi). Excessively high back pressures can aggravate drooling into the mold since decompression is usually kept to a minimum.

Decompression

In general, minimal decompression is used. Decompression tends to pull air back into the nozzle, causing splay in the next shot. Small amounts of decompression can be used to reduce drool.

Trial Preparation and Operation

Before beginning a trial, be sure that all conditions are optimized.

- Check the dryer for proper:
 - Air temperature at the hopper entrance.
 - Dew point of the drying air.
 - Airflow.
 - Hopper capacity relative to the size of sample to be dried.
- Clean the hopper and material-handling system thoroughly.
- Ensure proper mold-temperature control is available.
- Check the chiller and thermolator.
- Be sure the molding machine is clean. (See the section on start-up and purging.)
- Determine trial objectives. The purpose of the trial dictates the amount of material needed and the quality and number of parts required. For example, if the purpose is to obtain 5 good parts for testing, it is typical to run 200 shots on an untried mold. If the purpose is to make 50 parts, minimize cycle, or check part variability, the amount of material and time required will be much greater.

It is important to keep a complete record of operating conditions, pretrial preparations, changes, etc. during the trial. Forms for documenting trial procedures are provided for your convenience.

Completing Form 1 helps ensure that all needed preliminary operations have been performed. Form 2 (Pretrial Preparation) and Form 3 (Molding Conditions Record) can be used during the molding trial. Changes made to processing variables and effects of those changes during the trial or start-up can be documented on Form 3.

- Retain 30- to 60-g (1- to 2-oz) samples of the pellets and parts for follow-up testing of I_h.V. (inherent viscosity) or molecular weight.
- Document and save all setup conditions, changes to conditions, and their effects on part quality. Add comments regarding what worked well and what caused problems. Provide copies to all trial team members and to your Eastman representative. When the job goes to production, give copies to all persons involved.

Start-up

Start with a clean machine. If the machine is not purged, unmelted particles, gaseous splay, or a combination of problems will result. Ball checks are typically slow to purge and generally are not recommended; check rings are preferred.

Removing and cleaning the screw, check valve, nozzle, and barrel are the only effective means of purging difficult-to-remove high-temperature plastics.

Purge Materials

The material most effective in purging is a polymer similar to the material to be run. Polyethylene and polypropylene should be avoided because they can mix with the new material and cause streaks for extended periods of time. For difficult-to-remove materials, nozzle

and front barrel zone set points are sometimes increased up to 300°C (570°F) to soak and purge, then cooled back to running temperatures. Use caution and refer to the manufacturer's recommendations for the material used in the previous run.

After any cycle interruption of more than approximately 5 minutes, purging 3 to 5 shots is good practice.

Production Molding

Production Start-up

The processing window needs to be defined to establish a controlled molding process. The starting point for a production run is typically the same as the conditions used in the last molding trial or start-up run. The machine should be cleaned before production is started. After the window is defined, routine production operations should be set in the middle of the window so that normal variability does not result in scrap parts.

Cycle Uniformity or Rhythm

To maintain shot-to-shot consistency, it is best to maintain a constant cycle. With manual part removal (semiautomatic operation), a good rhythm should be established to maintain a constant time in the barrel from shot to shot.

Scrap Minimization

To minimize scrap, first determine the sources of scrap. The next step is to attempt to correct the largest sources first. Form 3 is provided as a tool for defining the problems that are causing scrap. After the cause is determined, refer to the "Troubleshooting Guide" at the end of this section for suggested solutions to various problems.

Use of Regrind

It is generally suggested that the regrind feeding rate be kept to 20% or less. This will help maximize part quality.

The quality of the regrind is as important as the quality of the virgin material.

Regrind should be:

- Kept free of contamination.
- Ground with sharp grinders to minimize fines and overheating.
- Dried.
- Fed at a constant ratio.

Some typical sources of contamination include:

- Hot stamping.
- Heat transfer tape.
- Contaminated parts.
- Purging.

Shutdown

In general, the feed can be shut off and molding continued on cycle until the screw is run dry. If you are changing to another material, purge with polycarbonate, acrylic, styrene, or commercial purge compound, run the screw dry, and turn off the power.

ALWAYS LEAVE THE SCREW FORWARD; otherwise a large slug of material must be remelted. If the slug does not fully melt before the screw is injected forward, check-ring damage may result.

Packaging and Part Handling

Parts with a high-gloss surface need to be protected from being scratched, dented, or otherwise damaged during handling. Packaging should be planned to protect the high-gloss finish of Eastman™ polymers.

Part III Secondary Operations

Parts made of Eastman™ polymers can be assembled using a wide variety of joining techniques. Solvent bonding, UV-curable adhesives, and ultrasonic welding are the most common methods of joining medical devices and are suitable techniques for joining parts made of Eastman™ polymers.

Methods for Joining Parts Made of Eastman™ Polymers

Chemical	<ul style="list-style-type: none">■ Solvent bonding■ Adhesives■ UV-curable adhesives
Mechanical	<ul style="list-style-type: none">■ Screws■ Inserts■ Snap-fit joints
Thermal	<ul style="list-style-type: none">■ Ultrasonic welding■ Electromagnetic■ Spin welding■ Hot plate

Solvent Bonding

Eastman™ polymers can be successfully bonded to PVC or polyurethane tubing. When bonding to PVC tubing, the following solvent systems are suggested:

- Cyclohexanone.
- 50/50 cyclohexanone/methylene chloride.
- 50/50 to 80/20 MEK/cyclohexanone.
- Methylene chloride.

Solvent bonding of PVC tubing to thermoplastic components is an important step in the fabrication of many medical devices.

When bonding to polyurethane tubing, the following solvent mixtures are suggested:

- Methylene chloride.
- Cyclohexanone.
- 50/50 to 20/80 cyclohexanone/MEK
- 50/50 to 20/80 cyclohexanone/methylene chloride.

Material Safety Data Sheets providing safety precautions that should be observed in handling and storing solvents are available from suppliers on request. You should obtain and review the available material safety information before handling any of these products. Appropriate industrial hygiene and other safety precautions recommended by their manufacturers should be observed. You must make your own determination of a solvent's suitability and completeness for your own use, for the protection of the environment, and for the health and safety of your employees and purchasers of your products.

In planning to use a bonding method, an Eastman technical service representative can provide you with information on acceptable mixtures and bonding methods. If you use other systems or methods, they should be tested first for bond strength, chemical stress-crack resistance, and safety.

Adhesive Systems

A variety of adhesive systems have been found to work well with Eastman™ polymers. For specific information on adhesive systems, contact your Eastman technical representative.

Ultrasonic Welding

Ultrasonic welding can be performed successfully using shear-type joints. Shear joints produce strong, hermetic bonds. Shear joints for Eastman™ polymers should closely follow the design suggested in Figure 32. In some limited situations, energy directors may work satisfactorily; but in most situations, the bond will not retain enough toughness for the application.

Figure 32

Ultrasonic Welding Eastman™ Polymers

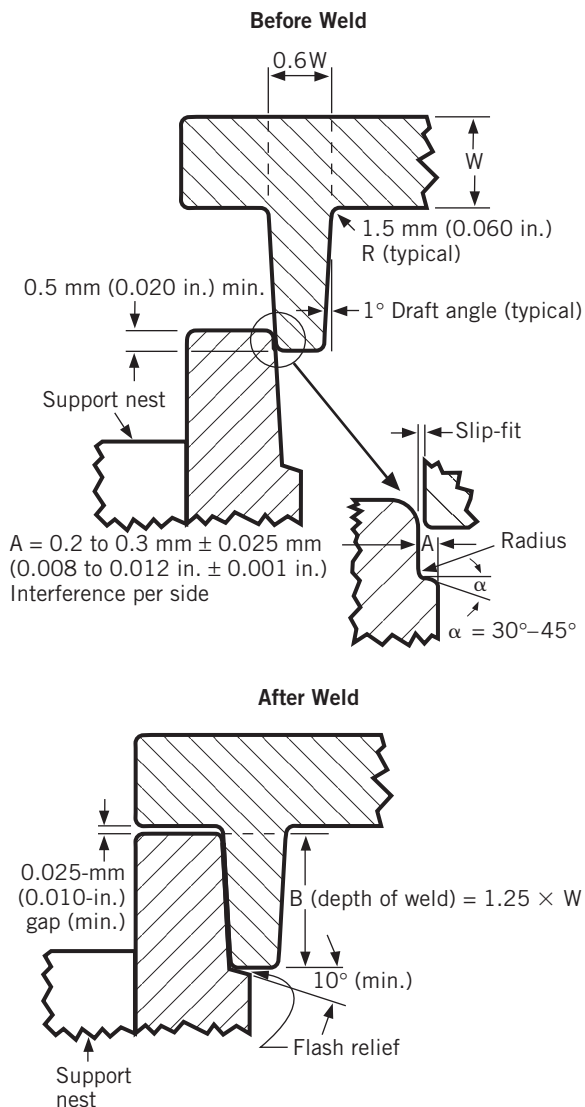

Ultrasonic Welding Advantages, Shear Joint vs. Energy Director

- Improved joint strength (2×)
- Improved joint toughness
- Reduced crack propagation behavior
- Improved distribution of loads (shear vs. leverage loading)
- Excellent sealing performance
- Improved interface melt fusion (less sensitive to additives)
- Improved control of joint flash

Typical Ultrasonic Welding Setup Conditions

- Horn type Aluminum or titanium
- Booster type Green (1:1)
- Welder power 1,000 watts (typical)
- Frequency 20 KHz
- Fixture/nest Rigid or semirigid
- Options Collapse control, constant weld-energy, computer control

Typical Ultrasonic Welding Conditions

- Welding time 0.5–1.0 s
- Hold time 1.0 s (min.)
- Welding pressure 0.207–0.345 MPa (30–50 psig)
- Trigger pressure Minimize
- Downspeed Minimize

Ultrasonic Staking

Ultrasonic staking is an assembly method in which the controlled melting and reforming of a plastic stud is used to capture or lock two components together. This method employs the use of a plastic stud on one part, which protrudes through a hole or slot on the second part. The vibrational energy applied by the ultrasonic horn is used to melt the plastic; the plastic is deformed by pressure applied to the staking horn. After deforming, the plastic quickly cools in its new position, locking the two parts together.

Ultrasonic staking offers several advantages, including short cycle times, good repeatability and control, tight locking, and the ability to form multiple stakes at one time. This has been proven as an acceptable method for joining parts manufactured from Eastman™ polymers to parts manufactured from other materials, such as steel.

There are several acceptable ultrasonic horn head forms. Typical dimensions and designs are shown in Figure 33.

Heat Staking

Heat staking is similar to ultrasonic staking, offering several of the same advantages. Heat staking has been shown to provide equal or greater strength compared to ultrasonic staking when proper staking guidelines are followed (Figure 33).

It is best to “dial-in” optimized conditions for each individual application. A good starting temperature for Eastar™ copolyesters and DuraStar™ polymers is 260°C (500°F). Raise

the temperature gradually until the polymer begins to stick to the horn, then back off by 6°–8°C (10°–15°F). This is the optimum horn temperature. The object is to melt the plastic post tips quickly without burning the material. The optimum pressure should also be “dialed-in.” Begin with low pressure, gradually increasing until a complete and properly shaped head is formed.

Figure 33

Ultrasonic/Heat-Staking Methods

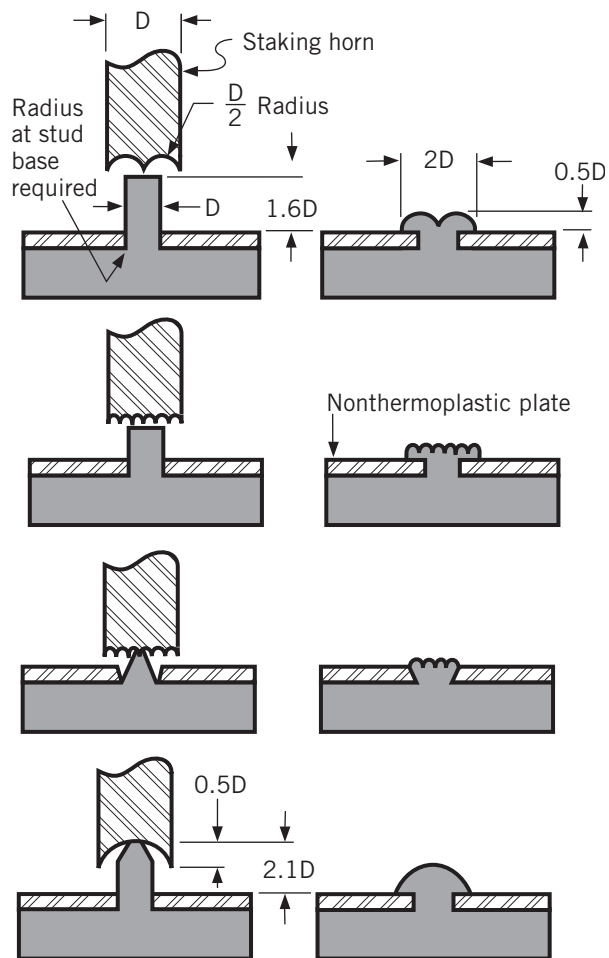

Welding Similar Materials

Ultrasonic and heat staking should be limited to applications where parts made of Eastar™ copolyesters and DuraStar™ polymers are staked to parts composed of other materials. We have found that when staking two Eastar™ copolyesters or two DuraStar™ polymers together, a slight melt interface forms where the deformed head pushes down against the mating piece. This can form “melt microcracks,” which can propagate under loading, forming a brittle joint. For best results, limit heat and ultrasonic staking to applications in which the plastics have a melting temperature difference of at least 22°C (40°F). We suggest using alternative joining methods (permanent snap-fits, ultrasonic welding with shear joints, hot plate welding, screws, inserts, adhesives, etc.) in this situation.

Other Fastening Techniques

Bosses, snap-fits, and locating features that take advantage of the ductility and toughness of these polymers should be designed using proper part design guidelines.

Many Eastman™ polymers have the required ductility to perform well in swaging and staking operations. The material can be softened using a heated horn or ultrasonic energy, and in many cases, the material can be swaged “cold.”

Conversions of metric/U.S. customary values may have been rounded off and therefore may not be exact conversions.

Part IV Troubleshooting

Troubleshooting Guide

The Troubleshooting Guide provides possible remedies for problems that may occur. Read across the top to find the problem being experienced, then search down the page for the highest priority remedy. If the number is followed by a plus sign, increase the variable shown. (Example: “Fill speed +” means to increase fill speed.) If the number has a minus sign, decrease the variable. If both a plus and minus are shown, it means that the setting is probably not correct; the proper setting may be either above or below the current one. If changing the first variable does not solve the problem, proceed to number 2, and so on. See also “‘Reading’ Parts as They Are Molded,” page 43.

One defect not listed in the table is a wavy surface. Waves are of two basic types: (1) very fine waves almost like fingerprints running along the flow front perpendicular to the flow direction and (2) much larger, irregular waves. The first type is ordinarily caused by slow fill speed or momentary changes in fill speed. The second type is usually caused by underpacking or by a mold that is too hot.

For possible cause, corrective action, and photos, please reference Eastman publication PPD-407, *Injection Molding Troubleshooting Guide for Eastar Copolyesters* or visit our website at <http://www.eastman.com>.

Descriptions of Terms in Troubleshooting Guide

Short Shots are simply shots that do not fill the mold completely. The plastic has not flowed far enough to fill the part, usually in areas farthest from the gate.

Brittle Parts break easily.

Voids or **Sinks** indicate that not enough material was packed into the part, resulting in an indentation of the surface (sink), or a cavity inside the part (void). These occur most often in thick walls and areas where ribs or bosses join the wall.

Bubbles of trapped air can show as lumps on the part surface in opaque materials, or as gas bubbles in clear materials. In clear materials, they typically appear with foamy tails pointing toward the gate. The foamy tails differentiate them from voids.

Splay is an appearance defect in the surface of the part, usually appearing as trapped gas bubbles being smeared across the surface as the flow front moves to fill the part. Splay can have several basic causes including moisture in the material (inadequate drying); overheating and outgassing; long holdup time either in the barrel or in a small dead spot; high fill speed causing high shear; part geometry causing high shear, usually at the gate or along a high-shear flow edge; trapped air because of very low back pressure on the screw; or air trapped as a result of part or runner geometry.

A second type of splay can come from unmelted or different-viscosity material. The basic cause of this is large temperature differences in the flow path, such as a cold nozzle or manifold or weak temperature control in a manifold. This appears very much like gaseous splay but, on very close examination, can sometimes be seen as unmelted particles.

Splay can also come from contamination by incompatible materials either left in the machine or mixed with the pellets.

Notice in the Troubleshooting Guide that the most probable cures for splay at the gate are different from those for splay at locations remote from the gate.

Sprue Sticking in clear materials refers to the sprue sticking in the mold, so it must be removed manually.

Part Sticking refers to the entire part sticking in the mold—not just the sprue.

Burning is the appearance of brown or black near vents, usually in the last area of the part to fill. It results from overheating of gasses (air) as the part fills.

Flash is plastic that flows into the parting line of the mold beyond the edges of the part and freezes to form thin, sheet-like protrusions from the part.

Brown Streaks refer to streaks in the part that start at the gate (or earlier, in the sprue) and flow across the part.

Discoloration refers to any nonuniform coloration, whether a general brown color such as that caused by overheating or streaky discoloration resulting from contamination.

Black Specks are tiny black particles that may be seen in the part.

Weld Lines (or **Knit Lines**) are present and not a problem in many cases. As used in the Troubleshooting Guide, the term refers to weld lines that are excessively visible, or to incomplete welding.

Jetting or **“Snake Flow”** appears in the part as a stream of frozen plastic that is coiled or curled inside the part. It results from the melt stream going through the gate and not impinging upon or spreading out across the mold surface but staying in a small stream at least for part of the shot.

Warpage refers to the part not being as straight or flat as the mold.

Troubleshooting Guide: Molding Amorphous Eastman™ Polymers

SUGGESTED REMEDIES Do 1 first, 2, 3, etc. + means increase - means decrease	PROBLEMS															
	Short Shots	Brittle Parts	Voids or Sinks ¹	Bubbles ¹	Surface Splay	Gate Splay	Sprue Stick-ing	Part Stick-ing	Burning	Flash	Brown Streaks	Discolor-ation	Black Specks	Weld Lines	Jetting	Warpage
DRYING																
Make Sure Polymer Is Dry		1	11		1	5	12	7		10		4-				
TEMPERATURES																
Melt Temp	6+	2-	7+		4±	6±	13-			7-		3-	6±	1+	3+	
Mold Temp	7+		9±					3-		8-				7+		1±
Nozzle or Hot Runner	8+				5-	2-					2-	6-			4+	4+
Decrease Sprue Temp							5									
Reduce ΔT (Barrel, Nozz, HR)					6											
PRESSURES																
Injection Pressure	2+	10-	3+			4-	8-	4-		1-				3+	2±	7-
Back Pressure	9+	6-	8+	1+	7±		11+					8-	4±			
Clamp Pressure										3+						
TIMES																
Mold Closed/Cooling			4-				6-	9±								2±
Injection Hold	5+		2+				9-	5-		4-				5+		8
Booster Time	3+		5+				10-	6-		2-				4+		9
Reduce Overall Cycle		4-						10				9-				
OTHER																
Injection Speed	4+		6-		2-	1-	4-		2-	5-				6+	1±	3-
Screw Speed		5-	10+	4±	10-							7-	5			
Decompression/Suckback				2-	3-	3-			5							
Use Sprue Break							7									
Cushion Size	1+		1+	3												
Ejection Uniformity								8								5
Purge Barrel ²				6	8				3		3	1	1			
Reduce Regrind %		7	12	8				11		9		5	3			
Check for Voids		8														
Check for Contamination		3		7	9				4		5	2	2			
HARDWARE																
Eliminate Sharp Corners					14											
Check Sprue/Nozzle Diam				5			1				4	10				
Incr. Gate Size/Streamline	10+		13+		11+	7+									5+	
Change Gate Location			14	9					6	12				9	6	11
Vent Size/Cleaning/Location	11+								1+	6-				2+		
Add Overflow @ Weld Area														8		
Use Different Size Machine	12+	9-			13					13+		11				
Repair Mold	13			10			15	13		11						
Increase Taper/Draft Angle							14	12								10
Check for Undercuts							3	1-								6-
Check Puller Design							2	2								
Fix Defective Check Ring											1	12	7			
Add Pin, etc. to Impinge Flow															7	

GENERAL GUIDELINES:

- Dry at 20°F or lower dew point.
- Dry for 6 hours.
- Use 1 CFM dry air per lb/hr of polymer used.
- Refer to Data Sheet for correct drying temperature.
- Use multidesiccant bed dryer (vs. tray or batch dryer).
- Select machine size to use 40% to 75% of capacity.
- Use sliding check ring with no hold up spots rather than ball check.
- Use full round runners.
- Use nozzle diameter greater than ~3/16 inch.
- Use short nozzle or nozzle with uniform heat control.
- Use moderate back pressure, usually 50 to 200 psi.
- Use slow to moderate screw spreads.
- Gate into thickest area of part with gate 50%–75% of part thickness.
- Vent mold 0.001 in. to 0.0012 in.

¹Voids typically have no foamy tail where air/gas bubbles often have a tail or trail.

²Purge with commercial purge compounds, acrylic, styrene; polyethylene and polypropylene are not usually good purge material for these polymers.

“Reading” Parts as They Are Molded

Often some very small marks and other visible features of a part can tell much about improvements needed in the molding process. It is usually best to examine the entire shot, including sprue, runner, and parts from all cavities when defining a problem in molding. It is also advisable to do this at the operating machine so that guesswork concerning molding conditions can be avoided. Watching how the screw travels during the entire injection period and relating that to the parts filling at the gate first (fountain flow) can help in understanding what is happening.

Part Failure: Causes and Analysis

In general, part failures can be minimized by utilizing proper design techniques, selecting the proper material, and processing the material properly. The “Part Failure Analysis Fish Bone” in Figure 34 demonstrates that there are many items that must be addressed to make a successful molded product. When a part fails, this chart can be used to guide the investigative process, which will hopefully point to the cause of failure and allow it to be remedied.

Figure 34

Part Failure Analysis Fish Bone

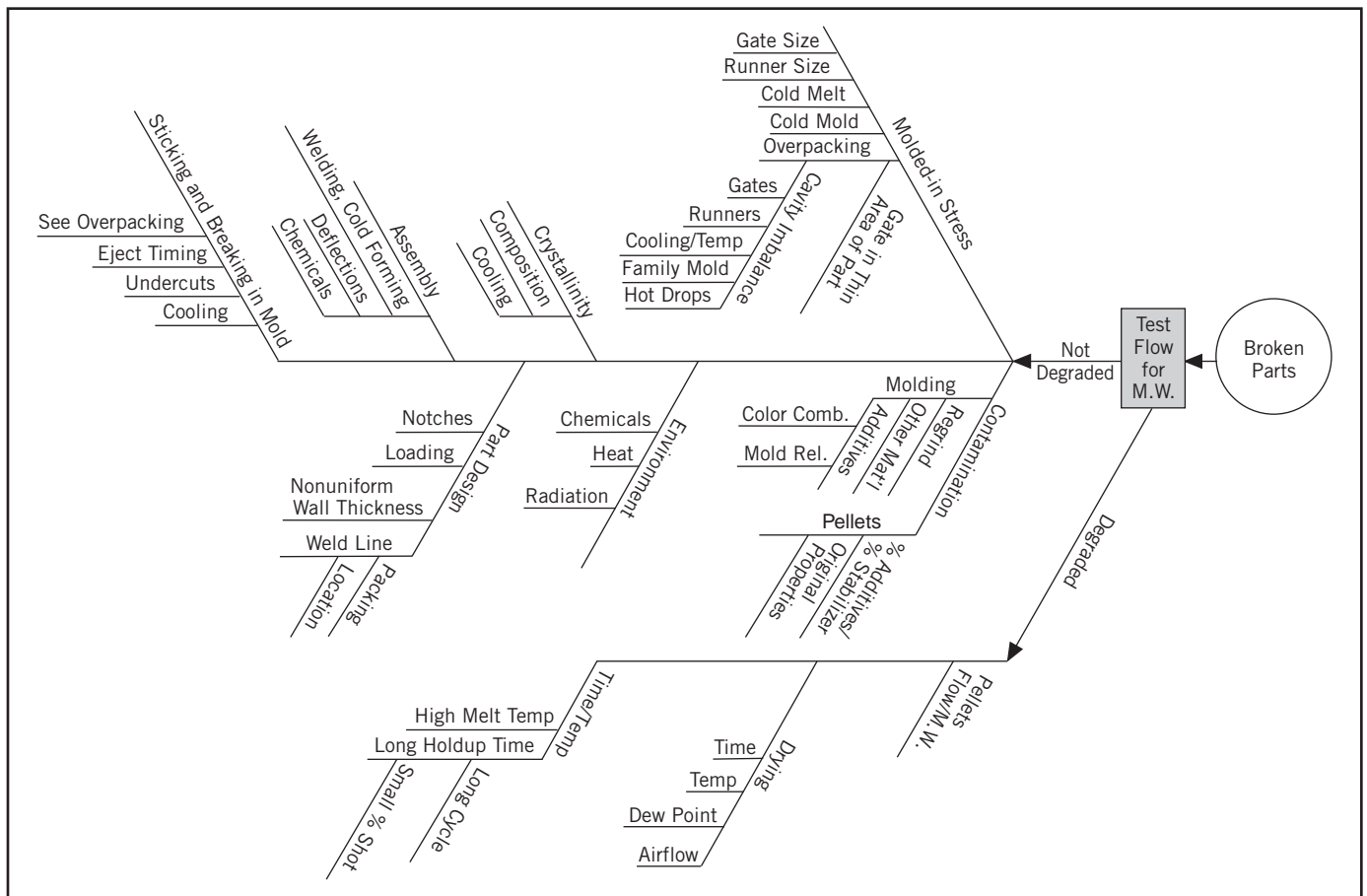

Form 1

PRETRIAL PREPARATION

Company _____ Date Sch. _____ Material

Location _____ Time Sch. _____ Pounds

Part _____ Received?

Trial Objectives (short demo, fast cycle, production run, etc.)

Technical Contact/Phone

DRYER

Desiccant Dryer _____, Capacity _____ lb, Temp _____ °C/°F, Time _____

PART AND SHOT (Part available to send in will eliminate several following items.)

Part Weight _____

Specific Gravity _____

Flow Length From Gate _____

Wall Thickness(es) _____

Gate Size _____

Number of Cavities _____

Shot Weight _____ ounces

Part Projected Area _____ sq. inches

MOLDING MACHINE

Molding Machine Capacity _____ ounces

Machine Clamp _____ tons

Inject Speed Profile Ability _____

Mold Cooling Available _____

Check Valve & Screw Type

Hot-Runner System/Type

OTHER INFORMATION

Form 2

MOLDING CONDITIONS RECORD

Company _____ Company Representative _____
 Date/Time _____
 Part _____
 Mold No. _____
 No. Cavities _____ Eastman Representative _____
 Machine No. _____ Size _____ Tons _____ Ounces _____
 Screw Type _____
 Check Ring Type _____
 Nozzle Orifice (size) _____ Hot Runner _____

	Run No.					
	Material—Color					
	Lot No.					
DRYING	Dew Point					
	Temperature					
	Time (hours)					
TEMPERATURES	Feed Zone					
	Center Zone					
	Front Zone					
	Nozzle					
	Hot Manifold					
	Actual Melt					
	Mold—Fixed					
PRESSURE	Mold—Moveable					
	Mold—Slides					
	Clamp					
	Filling Pressure					
	Packing Pressure					
CYCLE TIMES	Hold Pressure					
	Back Pressure					
	Injection, total screw forward					
	Fill Time					
	Pack Time					
	Hold Time					
	Cooling					
	Plasticizing					
MISCELLANEOUS	Total Open					
	Overall					
	Residence Time					
	Transfer Method					
	Transfer Position					
	Transfer Weight (%)					
COMMENTS	Decompression (length)					
	Cushion					
	Screw RPM					
	Total Shot Weight					
	Single Part (weight)					
	A —					
	B —					
	C —					
	D —					
	E —					

Form 3
Form for Identifying Problems That Are Causing Scrap

TITLE _____

COMPANY K Y Z Company

MACHINE NO. 12

NAME John Doe

PART NAME Utility Door

DATE 8/27/92 SHIFT 1 2 3 4 5

PART NO. 67-421

Scrap Reason	2	4	6	8	10	12	14	16	18	20	22	24	26	28	30	32	34	36	38	40	42	44	46	48	50	Total	% of Total
<i>Scratches</i>	X	X	X	X																						7	7.6
<i>Gate Block</i>	X	X	X	X	X	X	X	X	X	X	X	X	X	X	X	X	X	X	X	X	X	X	X	X	X	35	38.1
<i>Splay</i>	X	X	X	X	X	X																				12	13.0
<i>Short Shot</i>	X	X																								4	4.3
<i>Black Spcks</i>	X	X	X	X	X	X	X	X	X	X	X	X	X													21	22.8
<i>Flash</i>	X	X																								3	3.3
<i>Hot Stamp</i>	X	X	X	X	X																					10	10.9

Total Good 674 Total Scrap 92 Total Run 766 Total Scrap 92 100

Percent Total Scrap 12%

EASTMAN

NORTH AMERICA

Eastman Chemical Company Corporate Headquarters

P.O. Box 431
Kingsport, TN 37662-5280 U.S.A.

Telephone:
U.S.A. and Canada, 800-EASTMAN (800-327-8626)
Other Locations, (1) 423-229-2000
Fax: (1) 423-229-1193

www.eastman.com

LATIN AMERICA

Eastman Chemical Latin America

9155 South Dadeland Blvd.
Suite 1116
Miami, FL 33156 U.S.A.

Telephone: (1) 305-671-2800
Fax: (1) 305-671-2805

EUROPE / MIDDLE EAST / AFRICA

Eastman Chemical B.V.

Fascinatio Boulevard 602-614
2909 VA Capelle aan den IJssel
The Netherlands

Telephone: (31) 10 2402 111
Fax: (31) 10 2402 100

ASIA PACIFIC

Eastman (Shanghai) Chemical Commercial Company, Ltd. Jingan Branch

1206, CITIC Square
No. 1168 Nanjing Road (W)
Shanghai 200041, P.R. China

Telephone: (86) 21 6120-8700
Fax: (86) 21 5213-5255

Eastman Chemical Japan, Ltd.

AIG Aoyama Building 5F
2-11-16 Minami Aoyama
Minato-ku, Tokyo 107-0062 Japan

Telephone: (81) 3-3475-9510
Fax: (81) 3-3475-9515

Eastman Chemical Asia Pacific Pte. Ltd.

#05-04 Winsland House
3 Killiney Road
Singapore 239519

Telephone: (65) 6831-3100
Fax: (65) 6732-4930

Material Safety Data Sheets providing safety precautions, that should be observed when handling and storing Eastman products, are available online or by request. You should obtain and review the available material safety information before handling any of these products. If any materials mentioned are not Eastman products, appropriate industrial hygiene and other safety precautions recommended by their manufacturers should be observed.

Neither Eastman Chemical Company nor its marketing affiliates shall be responsible for the use of this information, or of any product, method or apparatus mentioned, and you must make your own determination of its suitability and completeness for your own use, for the protection of the environment and for the health and safety of your employees and purchasers of your products. NO WARRANTY IS MADE OF THE MERCHANTABILITY OR FITNESS OF ANY PRODUCT, AND NOTHING HEREIN WAIVES ANY OF THE SELLER'S CONDITIONS OF SALE.

DuraStar, Eastar, Eastman, Eastalloy, and Tritan are trademarks of Eastman Chemical Company.

Ampcoloy is a trademark of Ampco Metal Company. Diconite is a trademark of Lubrication Sciences, Inc. Lamina is a trademark of Anchor Lamina America, Inc. Moldmax is a trademark of Brush Wellman, Inc. Nicklon is a trademark of Bales Mold Service, Inc. Poly-Ond is a trademark of Poly-Plating, Inc. Teflon is a trademark of DuPont Company. Tungsten is a trademark of Palm, Inc. Vespel is a trademark of DuPont Company. WS2 is a trademark of Micro Surface Corporation.

© Eastman Chemical Company, 2008.

Publication PP-7D
March 2008

Printed in U.S.A.